

- The three main reactor types developed thus far—batch, continuous-stirred-tank, and plug-flow reactors—are useful for modeling many complex chemical reactors.
- Up to this point we have neglected a careful treatment of the fluid flow pattern within the reactor.
- In this chapter we explore some of the limits of this approach and develop methods to address and overcome some of the more obvious limitations.

## Scope of problem

- The general topic of mixing, even in the restricted context of chemical reactors, is an impossibly wide one to treat comprehensively.
- In this chapter, we will restrict ourselves to fluid-phase systems.
- One natural approach to describing mixing is to solve the equations of motion of the fluid.
- In fluid systems, the type of fluid flow is obviously important, and we should consider both laminar and turbulent flow, and various mechanisms of diffusion (molecular diffusion, eddy diffusion).
- Using fluid mechanics to describe all cases of interest is a difficult problem, both from the modeling and computational perspectives. Rapid developments in computational fluid dynamics (CFD), however, make this approach increasingly attractive [1].

- A second, classical approach to describing mixing is to use simple tests to experimentally probe the system of interest.
- These empirical testing approaches do not use any of the structure of the equations of motion, but they can provide some rough features of the mixing taking place in the system under study.
- In this chapter we first develop this classical approach, and find out what kinds of understanding it can provide.
- We also identify some of the limitations of this approach. Nauman and Buffham provide a more in-depth treatment of many of the classical topics covered in this chapter, and provide many further citations to the research literature [15].

- One might intuitively expect that to enhance mixing and reduce spatial variation in concentration, one should seek conditions that maximize the rate of diffusion.
- Although this notion is correct for mixing on the finest length scales, it is generally much more important in macroscopic scale processes to decrease variations on the larger length scales.
- Mixing in this regime is enhanced primarily by improving the convection, and diffusion plays only a small role.
- In simple terms, one does not expect to appreciably decrease the time required to mix the cream in one's coffee by increasing the coffee temperature (enhanced diffusion); one instead turns a spoon a few times (enhanced convection).
- On the finest length scales, mixing is accomplished readily for small molecules by the random process of molecular diffusion; in fact, the random molecular motions are the only effective mixing processes taking place on the finest length scales.

- Consider an arbitrary reactor with single feed and effluent streams depicted in the following figure

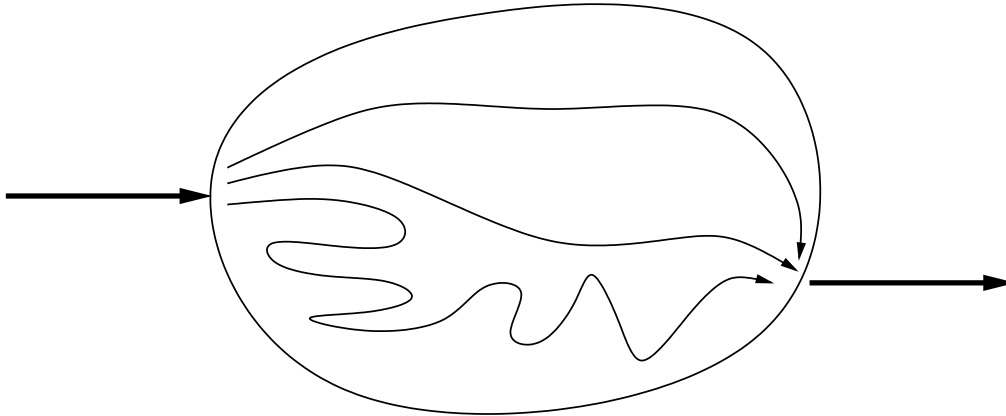

- Without solving for the entire flow field, which might be quite complex, we would like to characterize the flow pattern established in the reactor at steady state.
- The residence-time distribution of the reactor is one such characterization or measure of the flow pattern.

5 / 130

## Gedanken Experiment

- Imagine we could slip some inert tracer molecules into the feed stream and could query these molecules on their exit from the reactor as to how much time they had spent in the reactor.
- We assume that we can add a small enough amount of tracer in the feed so that we do not disturb the established flow pattern.
- Some of the tracer molecules might happen to move in a very direct path to the exit; some molecules might spend a long time in a poorly mixed zone before finally finding their way to the exit.
- Due to their random motions as well as convection with the established flow, which itself might be turbulent, we would start recording a distribution of residence times and we would create the residence-time probability density or residence-time distribution.
- If the reactor is at steady state, and after we had collected sufficient residence-time statistics, we expect the residence-time distribution to also settle down to a steady function.

6 / 130

Let  $p(\theta)$  represent the probability density or residence-time distribution, and  $P(\theta)$  the integrated form so

$$\begin{aligned} p(\theta)d\theta, & \quad \text{probability that a feed molecule spends time} \\ & \quad \theta \text{ to } \theta + d\theta \text{ in the reactor} \\ P(\theta), & \quad \text{probability that a feed molecule spends time} \\ & \quad \text{zero to } \theta \text{ in the reactor} \end{aligned}$$

The two versions of the probability function obviously contain the same information and are related by

$$P(\theta) = \int_0^\theta p(\theta')d\theta', \quad p(\theta) = \frac{dP(\theta)}{d\theta}$$

## Measuring the RTD

- As a thought experiment to define the RTD, querying tracer molecules on their exit from the reactor is a fine concept.
- But we plan to actually measure the RTD, so we require an implementable experiment with actual measurements.
- We cannot measure the time spent by a particular tracer molecule in the reactor; to us, all tracer molecules are identical. We can measure concentration of tracer molecules in the effluent, however, and that will prove sufficient to measure the RTD.
- Imagine an experiment in which we measure the concentration of tracer in the feed and effluent streams over some time period, while the reactor maintains a steady flow condition.
- From the definition of the RTD in the previous section, the effluent tracer concentration at some time  $t$  is established by the combined exit of many tracer molecules with many different residence times.

- The concentration of molecules that enter the reactor at time  $t'$  and spend time  $t - t'$  in the reactor before exiting is given by  $c_f(t')p(t - t')dt'$ .
- These molecules are the ones leaving the reactor at time  $t$  that establish effluent concentration  $c_e(t)$ , so we have

$$c_e(t) = \int_{-\infty}^t c_f(t')p(t - t')dt' \quad (8.1)$$

- The inlet and outlet concentrations are connected through this convolution integral with the residence-time distribution.
- If we conduct the experiment so that the feed tracer concentration is zero before an initial time  $t = 0$ , then the integral reduces to

$$c_e(t) = \int_0^t c_f(t')p(t - t')dt', \quad c_f(t) = 0, t \leq 0 \quad (8.2)$$

9 / 130

## Tracer concentrations to RTD

- Notice we can change the variable of integration in Equation 8.2 to establish an equivalent representation

$$c_e(t) = \int_0^t c_f(t - t')p(t')dt' \quad (8.3)$$

which is sometimes a convenient form.

- This connection between the inlet and outlet concentrations, and the RTD, allows us to determine the RTD by measuring only tracer concentrations.
- We next describe some of the convenient experiments to determine the RTD.

- In the step-response experiment, at time zero we abruptly change the feed tracer concentration from steady value  $c_0$  to steady value  $c_f$ .
- For convenience we assume  $c_0 = 0$ . Because the feed concentration is constant at  $c_f$  after time zero, we can take it outside the integral in Equation 8.3 and obtain

$$c_e(t) = c_f \int_0^t p(t') dt' = c_f P(t)$$

- So for a step-response experiment, the effluent concentration versus time provides immediately the integrated form of the residence-time distribution

$$P(\theta) = c_e(\theta)/c_f, \quad \text{step response} \quad (8.4)$$

## Pulse and impulse responses

- An impulse response is an idealized experiment, but is a useful concept. As we will see it provides the RTD directly rather than in the integrated form.
- To motivate the impulse-response experiment, imagine we abruptly change the inlet tracer concentration from zero to a large value and return it to zero after a short time as sketched in the following figure.

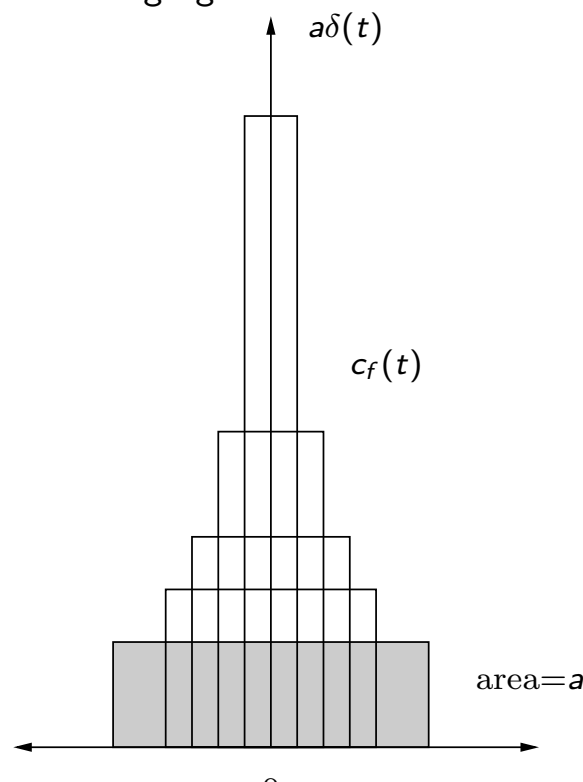

- The impulse response is an idealized limit of the pulse response. Consider a family of pulse tests of shorter and shorter duration  $\Delta t$ , as sketched in the figure.
- We maintain constant total tracer addition by spiking the feed with higher and higher concentrations so that the product  $c_f \Delta t = a$  is constant.
- The impulse response is the limit of this experiment as  $\Delta t \rightarrow 0$ . We call this limiting feed concentration versus time function the delta function,  $a\delta(t)$ . It is also called the Dirac delta function or an impulse, hence the name, impulse response.

## Impulse response

- The constant  $a$  is the amplitude of the delta function.
- The main property of the delta function is that, because it is so narrowly focused, it extracts the value of an integrand at a point in the interval of integration,

$$\int_{-\infty}^{\infty} g(t)\delta(t)dt = g(0), \quad \text{all } g(t) \quad (8.5)$$

$$\int_{-\infty}^{\infty} \delta(t)dt = 1, \quad \text{normalized}$$

- So if we can approximate  $c_f(t) = a\delta(t)$ , then we have from Equation 8.1

$$c_e(t) = a \int_{-\infty}^t \delta(t')p(t-t')dt' = ap(t)$$

- So for an experiment approximating an impulse, the effluent concentration versus time provides the residence-time distribution directly

$$p(\theta) = c_e(\theta)/a, \quad \text{impulse response} \quad (8.7)$$

- We next examine again the well-stirred reactor.

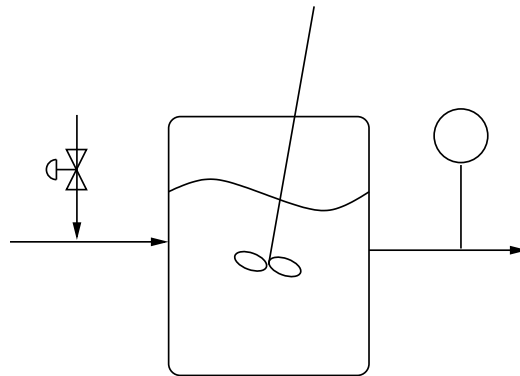

- Consider the following step-response experiment: a clear fluid with flowrate  $Q_f$  enters a well-stirred reactor of volume  $V_R$ .
- At time zero we start adding a small flow of a tracer to the feed stream and measure the tracer concentration in the effluent stream.
- We expect to see a continuous change in the concentration of the effluent stream until, after a long time, it matches the concentration of the feed stream.

15 / 130

## Mass balance

- Assuming constant density, the differential equation governing the concentration of dye in the reactor follows from Equation 4.38

$$\frac{dc}{dt} = \frac{Q_f}{V_R}(c_f - c), \quad c(0) = 0 \quad (8.8)$$

in which  $c$  is the concentration of the dye in the reactor and effluent stream.

- In Chapter 4, we named the parameter  $V_R/Q_f$  the “mean residence time” and gave it the symbol  $\theta$ .
- For our purposes here, we have already reserved  $\theta$  for the distribution of reactor residence times, so we define  $\tau = V_R/Q_f$ .

16 / 130



We already derived the solution to Equation 8.8, where

$$c(t) = (1 - e^{-t/\tau})c_f$$

so we have immediately

$$P(\theta) = 1 - e^{-\theta/\tau}$$

which upon differentiation gives

$$p(\theta) = \frac{1}{\tau}e^{-\theta/\tau}, \quad \text{CSTR residence-time distribution}$$

17 / 130

## CSTR as a game of chance

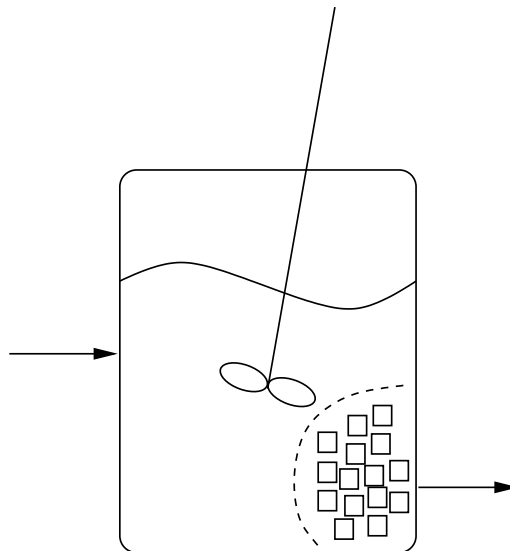

- Imagine we divide the reactor into a number of volume elements.
- At each time instant, some group of volume elements is withdrawn from the reactor, and new volume elements enter from the feed stream.
- The well-mixed assumption is equivalent to the statement that all volume elements are equally likely to be withdrawn from the reactor.
- One can view the mixing as quickly (instantaneously in the case of perfect mixing) randomizing the locations of the volume elements so that each one is equally likely to be nearest to the exit when the next element is withdrawn in the effluent stream.

18 / 130

- We have  $n$  volume elements, each with volume  $V_n = V_R/n$ .
- In time interval  $\Delta t$ , a volume of  $Q_f \Delta t$  leaves with the effluent stream.
- The number of elements leaving in the time interval is therefore  $Q_f \Delta t / V_n$  out of  $n$ , and the fraction of elements withdrawn is

$$f = \frac{Q_f \Delta t}{V_R} = \frac{\Delta t}{\tau}$$

- Now consider the probability that a particular volume element is still in the reactor after  $i$  time intervals. The probability of removal is  $f$ , so the probability of survival is  $1 - f$ .
- After  $i$  trials, each of which is independent, the probability of survival is the product  $(1 - f)^i$ . Therefore the probability that an element has residence (survival) time  $\theta = i\Delta t$  is

$$\tilde{p}(\theta) = \left(1 - \frac{\Delta t}{\tau}\right)^{\theta/\Delta t} \quad (8.9)$$

19 / 130

## The continuous time limit

- We now take the limit as  $\Delta t \rightarrow 0$ . Recall from calculus

$$\lim_{x \rightarrow 0} (1 + ax)^{1/x} = e^a$$

- Taking the limit and using this result in Equation 8.9 gives

$$\tilde{p}(\theta) = e^{-\theta/\tau}$$

which, after normalization, is again the residence-time distribution of the CSTR.

- The normalization constant is computed by integration

$$\int_0^{\infty} \tilde{p}(\theta) d\theta = \int_0^{\infty} e^{-\theta/\tau} d\theta = \tau$$

so the residence-time distribution is

$$p(\theta) = \frac{1}{\tau} e^{-\theta/\tau} \quad (8.10)$$

which is plotted in the next figure for a variety of mean residence times.

20 / 130

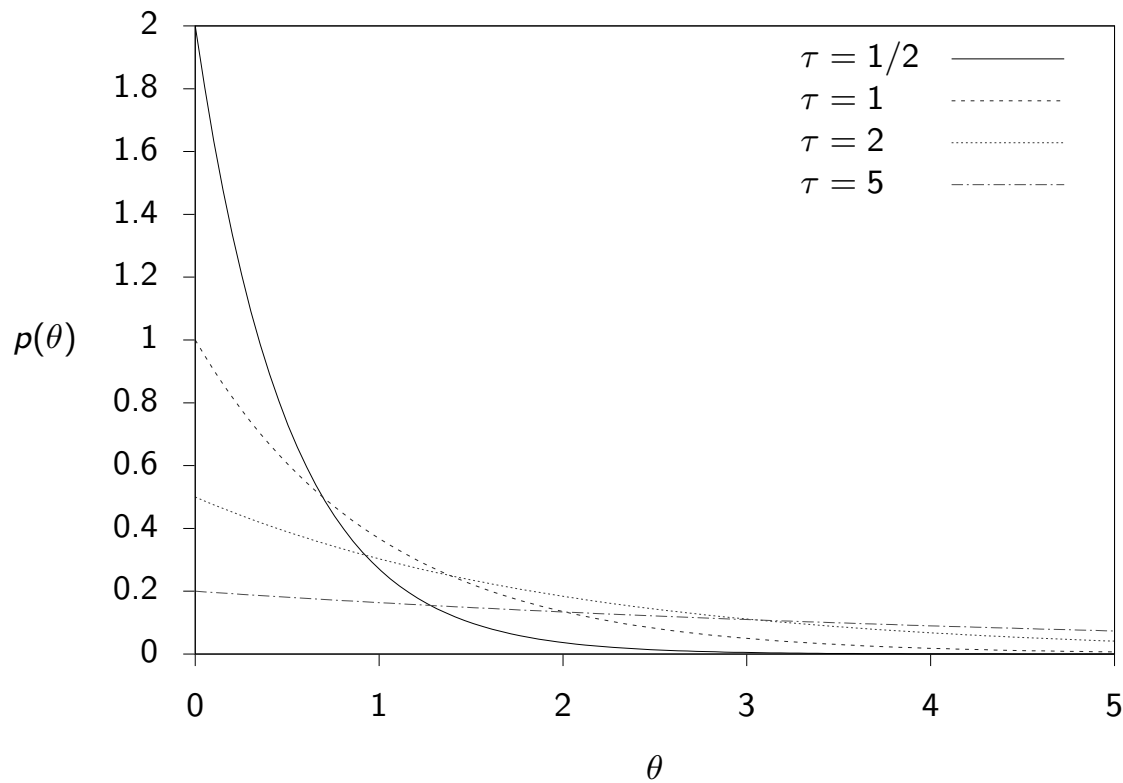

## Mean of the CSTR RTD

- We next compute the mean of this distribution. An integration by parts produces

$$\begin{aligned}
 \bar{\theta} &= \int_0^{\infty} \theta p(\theta) d\theta = \frac{1}{\tau} \int_0^{\infty} \theta e^{-\theta/\tau} d\theta \\
 &= \frac{1}{\tau} \left[ -\tau \theta e^{-\theta/\tau} - (\tau)^2 e^{-\theta/\tau} \right] \Big|_0^{\infty} \\
 &= \tau
 \end{aligned}$$

and we have established that the mean of the RTD for the CSTR is indeed  $\tau = V_R/Q_f$ .

- We can therefore compactly write Equation 8.10 as

$$p(\theta) = \frac{1}{\bar{\theta}} e^{-\theta/\bar{\theta}} \quad (8.11)$$

- Notice the exponential distribution tells us that it is unlikely for a volume element to remain in this reactor for long because at each instant there is a constant probability that the element is withdrawn in the effluent.

## Plug-Flow Reactor (PFR) and Batch Reactor

- The simple flow pattern in the PFR produces a simple residence-time distribution.

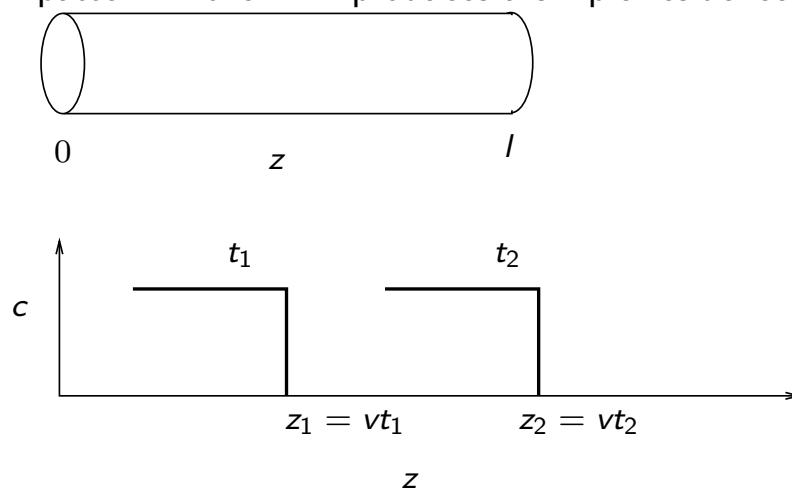

- Consider a step test in which the reactor is initially free of tracer and we increase the feed tracer concentration from zero to  $c_f$  at time zero.

- As shown in the figure, the tracer travels in a front that first reaches the reactor exit at time  $t = l/v$ , in which  $v$  is the velocity of the axial flow and  $l$  is the reactor length.
- From these physical considerations, we can write the reactor tracer concentration immediately

$$c(t, z) = \begin{cases} 0, & z - vt > 0 \\ c_f, & z - vt < 0 \end{cases} \quad (8.12)$$

- For  $z - vt > 0$ , the tracer front has not reached location  $z$  at time  $t$  so the tracer concentration is zero.
- For  $z - vt < 0$ , the front has passed location  $z$  at time  $t$  and the tracer concentration is equal to the feed value  $c_f$ .

## The step function

- It is convenient to introduce the unit step or Heaviside function to summarize this result.
- The Heaviside function is defined as follows

$$H(t) = \begin{cases} 0, & t < 0 \\ 1, & t > 0 \end{cases} \quad (8.13)$$

- Because we are armed with the delta function, we can even consider differentiating this discontinuous function to obtain the relationship

$$\frac{dH(t)}{dt} = \delta(t) \quad (8.14)$$

- Equation 8.12 can then be summarized compactly by

$$c(t, z) = c_f H(t - z/v)$$

so the effluent tracer concentration is given by

$$c_e(t) = c_f H(t - l/v) = c_f H(t - V_R/Q_f)$$

and the integrated form of the residence-time distribution is therefore

$$P(\theta) = H(\theta - V_R/Q_f)$$

- We can differentiate this result using Equation 8.14 to obtain

$$p(\theta) = \delta(\theta - V_R/Q_f)$$

- In other words, all tracer molecules spend exactly the same time  $V_R/Q_f$  in the reactor. The mean of this distribution is then also  $V_R/Q_f$ , which is verified by using Equation 8.5

$$\bar{\theta} = \int_0^{\infty} \theta \delta(\theta - V_R/Q_f) d\theta = V_R/Q_f$$

which shows that  $V_R/Q_f$  is the mean residence time for the PFR as well as the CSTR, even though the residence-time distributions of these two reactors are quite different.

27 / 130

## PFR RTD — Summary

- We can compactly summarize the RTD for the plug-flow reactor by

$p(\theta) = \delta(\theta - \bar{\theta})$	PFR and	(8.15)
$P(\theta) = H(\theta - \bar{\theta})$	batch reactors	

- Likewise, the RTD for a batch reactor is immediate. All material is charged to the reactor at time  $t = 0$  and remains in the reactor until the final batch time, which we may call  $\bar{\theta}$ .
- Then Equations 8.15 also apply to the batch reactor.

28 / 130

Consider dividing the volume of a single CSTR into  $n$  equal-sized CSTRs in series

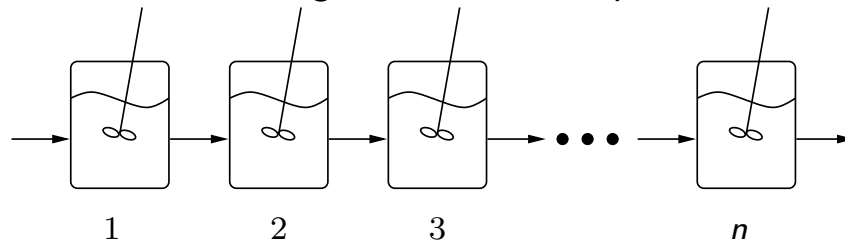

If the single CSTR has volume  $V_R$  and residence time  $\tau = V_R/Q_f$ , each of the CSTRs in series has volume  $V_R/n$  and residence time  $\tau/n$ .

If we solve for the effluent concentration after an impulse at time zero, we can show

$$p(\theta) = \left(\frac{n}{\tau}\right)^n \frac{\theta^{n-1}}{(n-1)!} e^{-n\theta/\tau} \quad (8.16)$$

## CSTRs in series

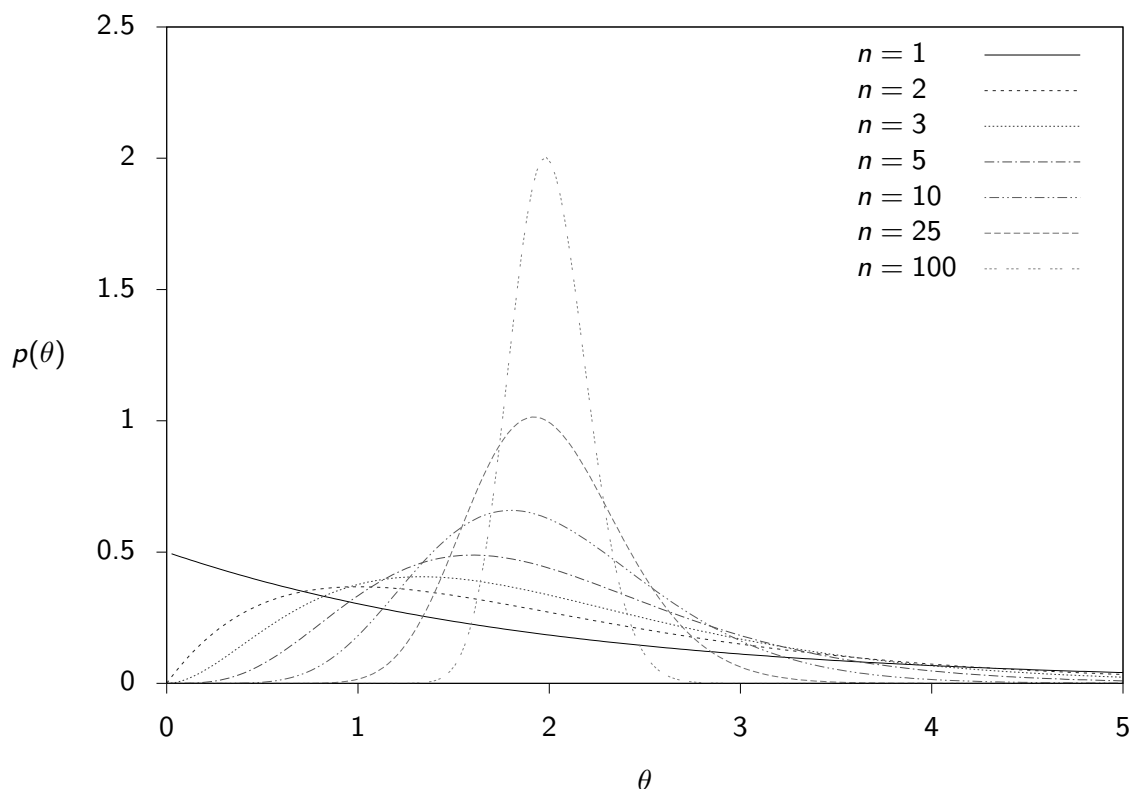

Notice the residence-time distribution becomes more narrowly focused at  $\tau$  as  $n$  increases. In fact Equation 8.16 for large  $n$  is another approximation for  $\delta(\theta - \tau)$ .

If we integrate Equation 8.16 we obtain

$$P(\theta) = \frac{\gamma(n, n\theta/\tau)}{\Gamma(n)} \quad (8.17)$$

You can perform integration by parts on Equation 8.16 to obtain a series representation

$$P(\theta) = 1 - \left( 1 + \frac{n\theta/\tau}{1!} + \frac{(n\theta/\tau)^2}{2!} + \dots + \frac{(n\theta/\tau)^{n-1}}{(n-1)!} \right) e^{-n\theta/\tau} \quad (8.20)$$

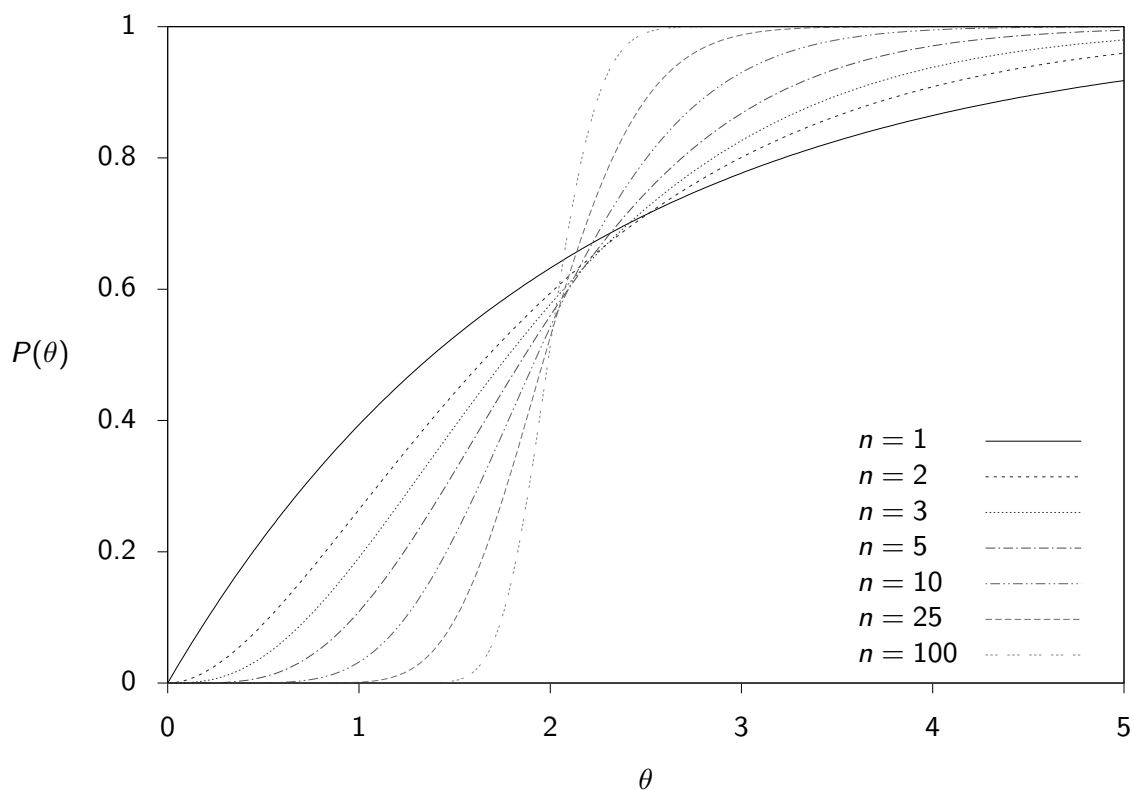



## Dispersed Plug Flow

- Ideal plug flow may not be realized in many packed-bed reactors. We develop next a model that allows for deviations from plug flow.
- In the PFR a change in the feed concentration travels as a perfect front. But measurements in actual packed-bed reactors may show a fair amount of spreading or dispersion as this front travels through the reactor.

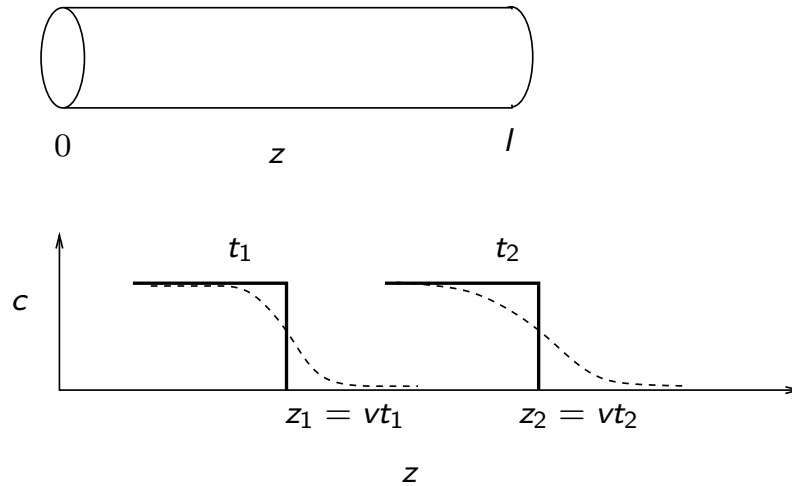

33 / 130

## Dispersed Plug Flow

- The dispersed plug-flow model given in Equation 8.21 allows for this spreading phenomenon.
- A diffusion-like term has been added to the mass balance. The coefficient,  $D_l$ , is called the dispersion coefficient.

$$\underbrace{\frac{\partial c}{\partial t}}_{\text{accumulation}} = \underbrace{-v \frac{\partial c}{\partial z}}_{\text{convection}} + \underbrace{D_l \frac{\partial^2 c}{\partial z^2}}_{\text{diffusion}} \quad (8.21)$$

34 / 130

## 2nd derivative and boundary conditions

- Given diffusion in the tube, the inlet boundary condition is no longer just the feed condition,  $c(0) = c_f$ , that we used in the PFR.
- To derive the boundary condition at the inlet, we write a material balance over a small region containing the entry point, and consider diffusion and convection terms.

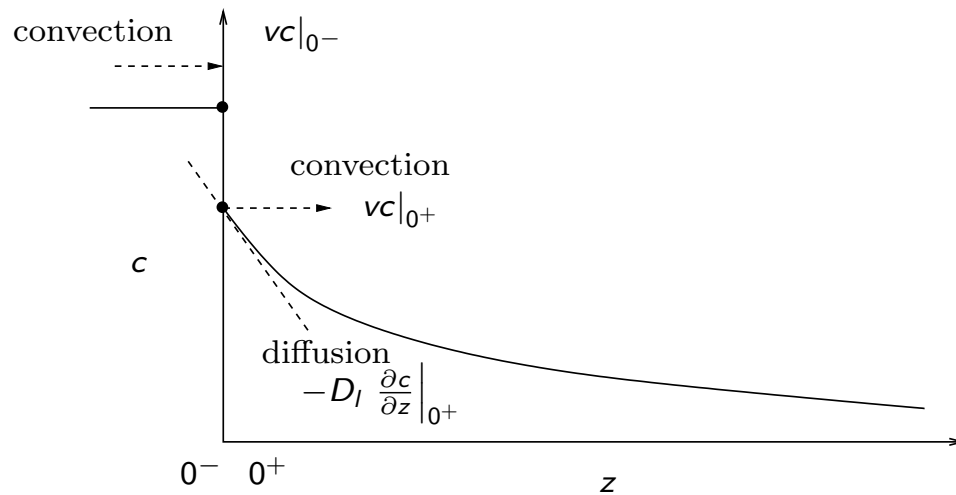

35 / 130

## Inlet boundary condition

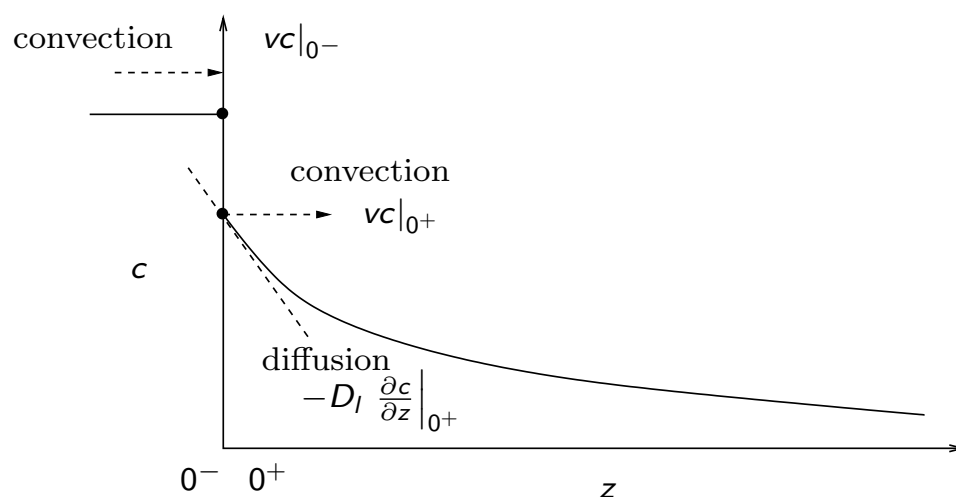

$$vc|_{0-} = vc|_{0+} - D_l \frac{\partial c}{\partial z} \Big|_{0+} \quad z = 0$$

36 / 130

- The diffusion term introduces a second-order derivative in Equation 8.21, so we now require two boundary conditions.
- We specify a zero slope condition at the tube exit.

$$\begin{aligned}vc|_{0^-} &= vc|_{0^+} - D_l \left. \frac{\partial c}{\partial z} \right|_{0^+} & z = 0 \\ \frac{\partial c}{\partial z} &= 0 & z = l\end{aligned}\tag{8.22}$$

- These two boundary conditions have become known as Danckwerts boundary conditions [4], but they were derived at least 45 years prior to Danckwerts in a classic paper by Langmuir [13].

37 / 130

It is now convenient to introduce a coordinate moving with a scaled velocity

$$x = \frac{z - vt}{\sqrt{4D_l t}} = \frac{\bar{z} - t/\tau}{\sqrt{4Dt/\tau}}$$

in which

$$D = \frac{D_l}{vl} = \frac{D_l \tau}{l^2}, \quad \text{dimensionless dispersion number}$$

Transforming variables from  $z$  and  $t$  in Equation 8.21 to  $x$  gives

$$\frac{d^2 c}{dx^2} + 2x \frac{dc}{dx} = 0\tag{8.23}$$

Rather than use the Danckwerts boundary conditions, we can approximate the behavior with the following simplified boundary conditions

$$\begin{aligned}c &= 1, & x &= -\infty \\ c &= 0, & x &= \infty\end{aligned}\tag{8.24}$$

These boundary conditions correspond to stating that  $c = 0$  for  $z, t$  values corresponding to arbitrarily long times before the step change arrives, and that  $c = 1$ , for  $z, t$  values corresponding to arbitrarily long times after the step change has passed. See Exercise 8.10 for comparing the dispersed PFR RTD with Danckwerts boundary conditions to the one we calculate here with the simplified boundary conditions.

38 / 130

The solution to Equation 8.23 with boundary conditions listed in Equations 8.24 is

$$c(x) = 1/2 \left[ 1 - \frac{2}{\sqrt{\pi}} \int_0^x e^{-t^2} dt \right]$$

The integral can be expressed in terms of the error function, which is defined as

$$\text{erf}(x) = \frac{2}{\sqrt{\pi}} \int_0^x e^{-t^2} dt \quad (8.25)$$

Substituting in the original variables and setting  $\bar{z} = 1$  to obtain the response at the reactor outlet as a function of time gives

$$c(\bar{z} = 1, t) = 1/2 \left[ 1 - \text{erf} \left( \frac{1 - t/\tau}{\sqrt{4Dt/\tau}} \right) \right]$$

and we have calculated the integrated form of the RTD for the dispersed PFR with simplified boundary conditions

$$P(\theta) = 1/2 \left[ 1 - \text{erf} \left( \frac{1 - \theta/\tau}{\sqrt{4D\theta/\tau}} \right) \right] \quad (8.26)$$

Equation 8.26 is plotted in Figure 8.10 for  $\tau = 2$  and various dispersion numbers  $D$ .

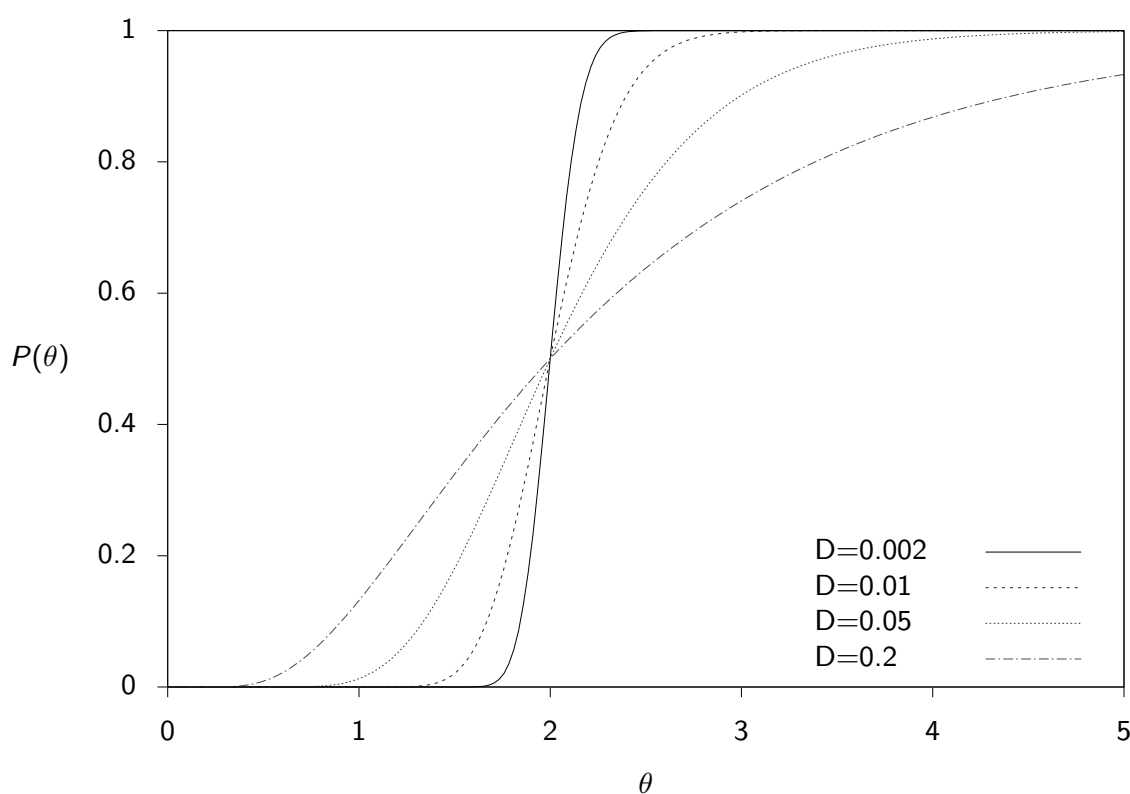

Figure 8.10:  $P(\theta)$  versus  $\theta$  for plug flow with dispersion number  $D$ ,  $\tau = 2$ .

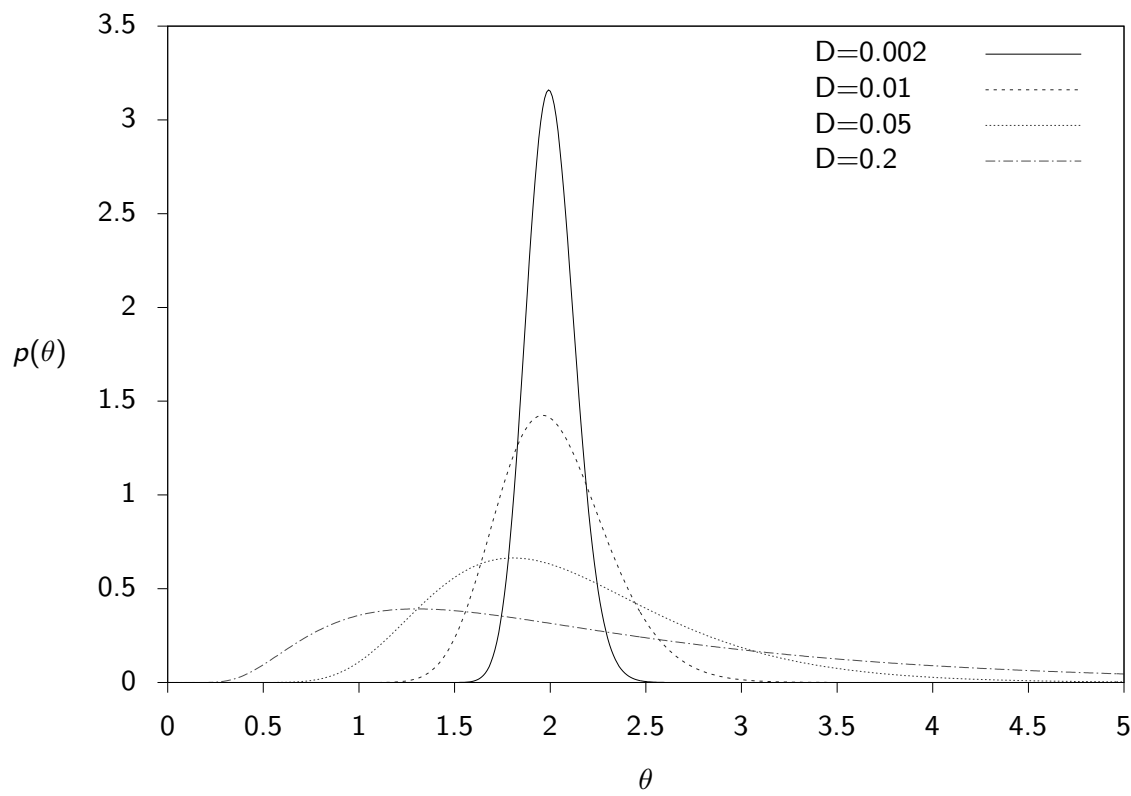

Figure 8.11: Residence-time distribution  $p(\theta)$  versus  $\theta$  for plug flow with dispersion number  $D$ ,  $\tau = 2$ .

We can differentiate Equation 8.26 to obtain the dispersed plug-flow RTD

$$p(\theta) = \frac{1}{4\tau\sqrt{\pi D}} \frac{1 + \tau/\theta}{\sqrt{\theta/\tau}} \exp\left(-\left(\frac{1 - \theta/\tau}{\sqrt{4D\theta/\tau}}\right)^2\right) \quad (8.27)$$

This RTD is plotted in Figure 8.11.

The dispersion number,  $D$ , is related to another dimensionless group, the mass-transfer analog of the inverse of the Péclet number,

$$\text{Pe} = \frac{vl}{D_A}, \quad \frac{1}{\text{Pe}} = \frac{D_A}{vl}$$

which measures the rate of diffusion compared to the rate of convection. The key difference is the Péclet number contains the molecular diffusivity,  $D_A$ , and the dispersion number contains the effective axial dispersion coefficient,  $D_I$ . Levenspiel makes a compelling case that these two quantities have different origins and motivations and deserve different names. To further complicate matters, the inverse of the Péclet number is often called the Bodenstein number in European literature. Weller [20] provides an interesting discussion of the history of the literature on the Bodenstein number, which does not appear to have been defined or used by Bodenstein, but was defined and used by Langmuir [13].

We modify Equation 8.21 for dispersed plug flow to account for chemical reaction,

$$\frac{\partial c_j}{\partial t} = -v \frac{\partial c_j}{\partial z} + D_{jl} \frac{\partial^2 c_j}{\partial z^2} + R_j \quad (8.28)$$

Danckwerts boundary conditions, as given in Equations 8.22, can be applied without change.

Up to this point in the text, we have solved *exclusively steady-state* profiles in tubular reactors. Obviously tubular reactors experience a start-up transient like every other reactor, and this time-dependent behavior is also important and interesting. Calculating the transient tubular-reactor behavior involves solving the partial differential equation (PDE), Equation 8.28, rather than the usual ODE for the steady-state profile. Appendix A describes the method we use for this purpose, which is called orthogonal collocation.

## Transient start-up of a PFR

### Example 8.1: Transient start-up of a PFR

Compute the transient behavior of the dispersed plug-flow reactor for the isothermal, liquid-phase, second-order reaction

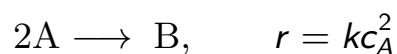

The reactor is initially filled with solvent. The kinetic and reactor parameters are given in Table 8.1.

Parameter	Value	Units
$k$	0.5	L/mol·min
$c_{Af}$	1	mol/L
$D_{Al}$	0.01	m <sup>2</sup> /min
$v$	0.5	m/min
$l$	1	m

Table 8.1: Mass-transfer and kinetic parameters for Example 8.1.

## Solution I

The mass balance for component A is

$$\frac{\partial c_A}{\partial t} = -v \frac{\partial c_A}{\partial z} + D_{AI} \frac{\partial^2 c_A}{\partial z^2} - 2kc_A^2$$

The boundary conditions are

$$vc_{Af} = vc_A|_{0^+} - D_{AI} \left. \frac{\partial c_A}{\partial z} \right|_{0^+}, \quad z = 0$$

$$\left. \frac{\partial c_A}{\partial z} \right|_l = 0, \quad z = l$$

Finally, an initial condition is required

$$c_A(z, t) = 0, \quad t = 0$$

45 / 130

## Solution II

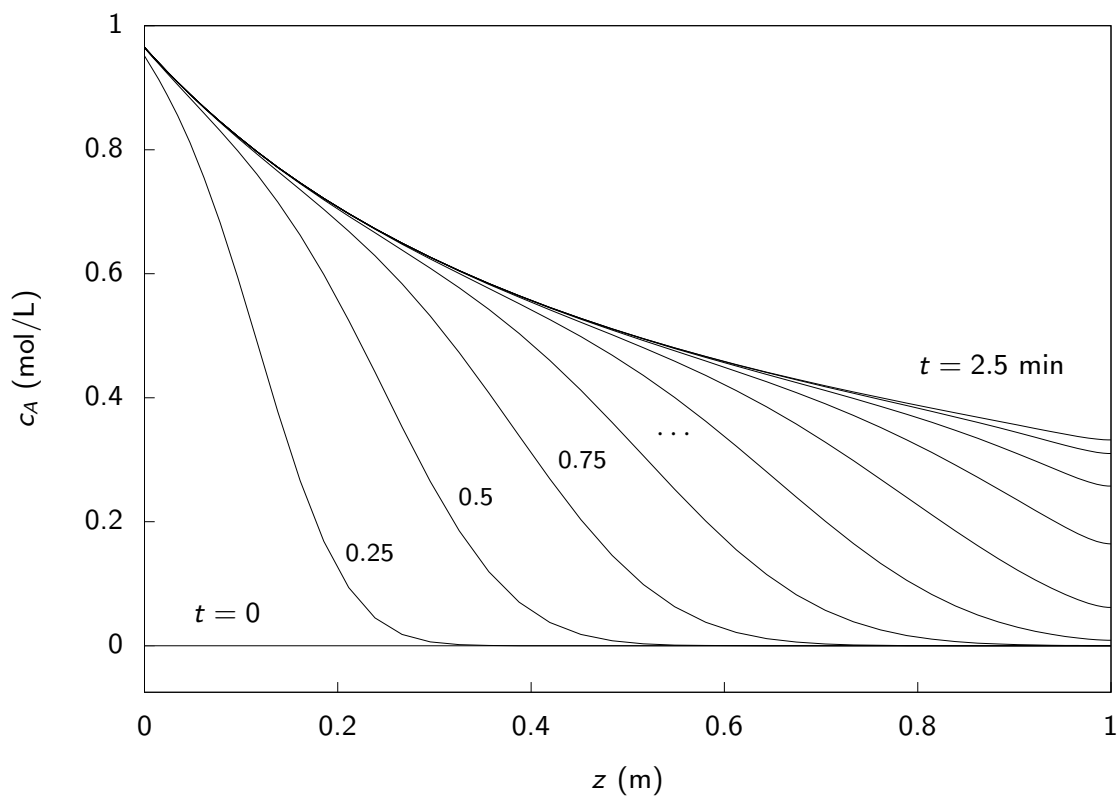

46 / 130

Figure 8.12: Start-up of the tubular reactor;  $c_A(z, t)$  versus  $z$  for various times,  $0 \leq t \leq 2.5$ ,  $\Delta t = 0.25$ .

Figure 8.12 shows the transient profiles. We see the reactor initially has zero A concentration. The feed enters the reactor and the A concentration at the inlet rises rapidly. Component A is transported by convection and diffusion down the reactor, and the reaction consumes the A as it goes. After about  $t = 2.5$ , the concentration profile has reached its steady value. Given the low value of dispersion in this problem, the steady-state profile is close to the steady-state PFR profile for this problem.

47 / 130

## Example—order matters

### Example 8.2: Order matters

- Consider two arrangements of a PFR and CSTR of equal volume in series as shown below

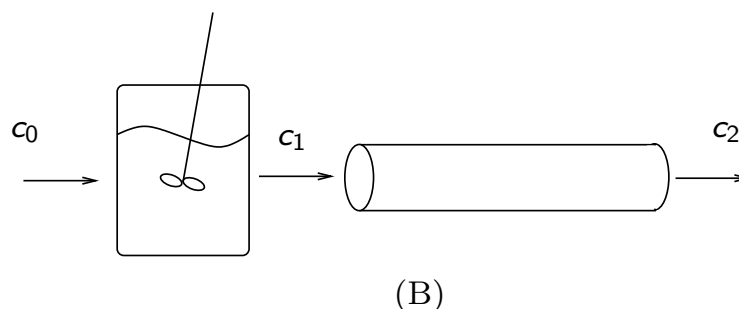
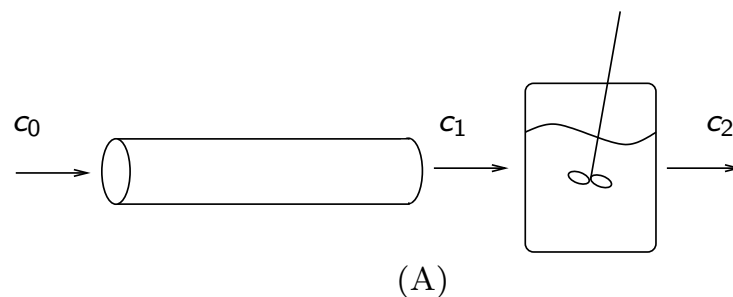

- What are the residence-time distributions for the two reactor systems? What are the overall conversions for the two systems?

□

48 / 130



- Consider a unit step test for the CSTR–PFR arrangement. The outlet concentration for the CSTR is given by

$$c_1(t) = 1 - \exp(-t/\tau)$$

- That feed concentration to the PFR is then simply delayed by  $\tau$  time units to give for the CSTR–PFR arrangement.

$$p(\theta) = (1 - \exp(-(t - \tau)/\tau)) H(t - \tau)$$

## Reverse order

- Next consider a unit step test into the PFR–CSTR arrangement. For this case the intermediate stream is given by a delayed step input

$$c_1(t) = H(t - \tau)$$

- With this feed into the CSTR, the effluent is merely the CSTR response to a unit step change after we shift the starting time of the step forward  $\tau$  time units,

$$c_2(t) = (1 - \exp(-(t - \tau)/\tau)) H(t - \tau)$$

- so again for this case

$$p(\theta) = (1 - \exp(-(t - \tau)/\tau)) H(t - \tau)$$

- and the two residence-time distributions are equal.

- The steady-state conversions for both arrangements are also simply calculated. For a single CSTR, the steady-state inlet and outlet concentrations are related by

$$c_o/c_i = \frac{-1 + \sqrt{1 + 4k\tau c_i}}{2k\tau c_i} = C(c_i)$$

- For a single PFR, the inlet and outlet concentrations are related by

$$c_o/c_i = \frac{1}{1 + k\tau c_i} = P(c_i)$$

- So we wish to compare  $P(C(c_0))$  for the CSTR–PFR case and  $C(P(c_0))$  for PFR–CSTR case.
- Because we are not even told  $k\tau c_0$ , we check over a range of values.

51 / 130

## Outcome of the calculation

- The figure displays the result. We see that the conversions are *not* the same and that *the PFR–CSTR gives higher conversion* (lower outlet concentration) than the CSTR–PFR for all values of  $k\tau c_0$  for a second-order reaction.

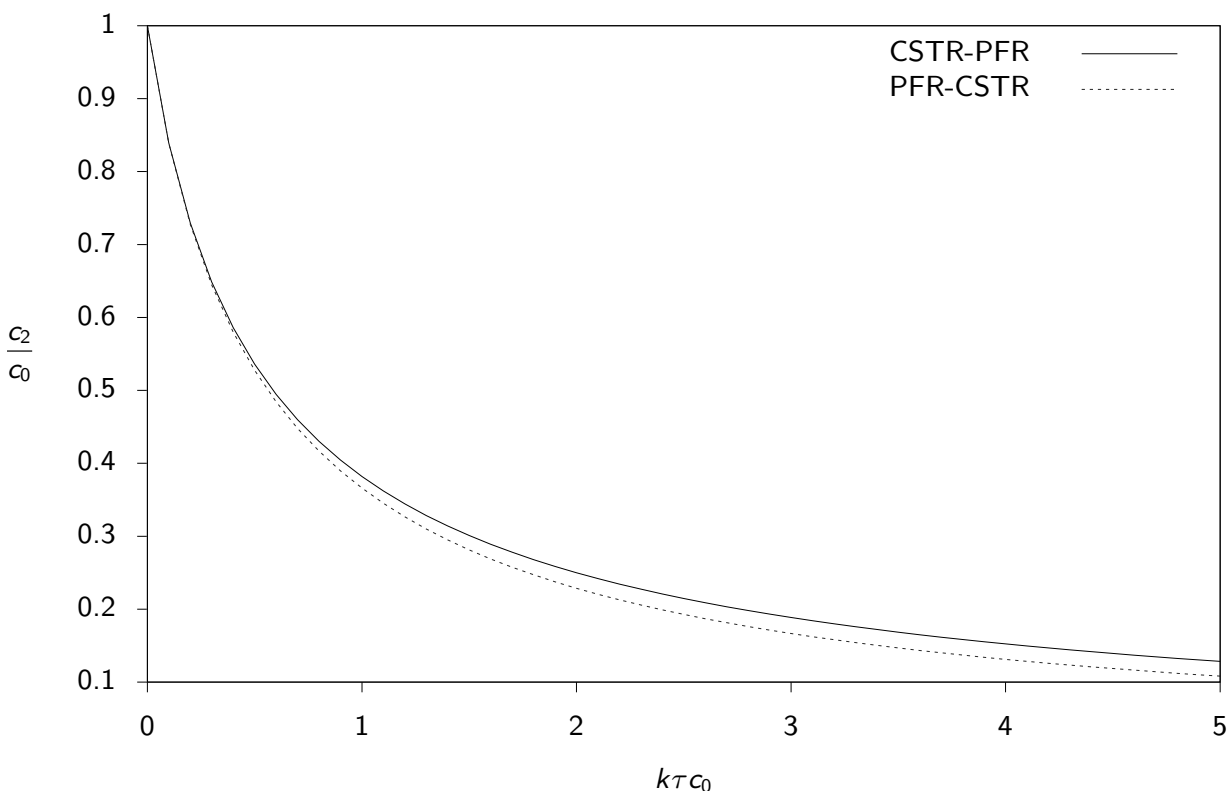

52 / 130

## Limits of Reactor Mixing I

We have seen in the previous section that complete knowledge of the reactor residence-time distribution is insufficient to predict the reactor performance. Although we have characterized completely the time tracer molecules spend in the reactor, we have not characterized their surrounding environment in the reactor during this time.<sup>1</sup> In the literature these two effects are sometimes termed **macromixing**: the distribution of residence times of molecules moving with the flow; and **micromixing**: the exchange of material between different volume elements during their residence times. Although we may find it instructive to separate these two phenomena in the simple reactor mixing models under discussion, in actual reactors this separation may be unrealistic. Accurate prediction of reactor performance may require solution or approximate solution of the equations of motion for the fluid, including material transport due to diffusion. In defense of the simple mixing models, however, they do provide another important insight. We can determine the limits of achievable mixing consistent with a measured reactor residence-time distribution. These mixing limits do provide some insight into the limits of achievable reactor performance, although this connection remains an active area of research as discussed in section 8.4.

<sup>1</sup>If someone were to characterize your learning in this course by measuring your hours spent in the classroom (RTD), they would hopefully obtain a positive correlation between learning and residence time. But we would naturally want to evaluate the environment inside the classroom during these hours if we were going to make more accurate predictions of learning. We would want to know if the instructor was prepared for lecture and saying reasonable things, if the students were attentive or asleep, and so on.

## Complete Segregation I

Imagine we know a reactor RTD,  $p(\theta)$ , either through direct measurement in a tracer experiment or solution of the equations of motion or some other means. We know from Example 8.2 that this constraint does not tell us the complete state of mixing in the reactor. We define next the two extreme limits of mixing consistent with the given RTD. These ideas were laid out in influential papers by Danckwerts and Zwietering. The first limit is called complete segregation; it is the limit of no mixing between volume elements. We can realize this limit by considering the ideal reactor depicted in Figure 8.15.

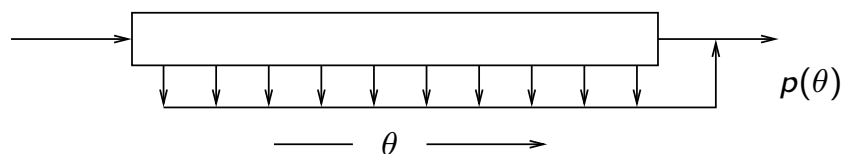
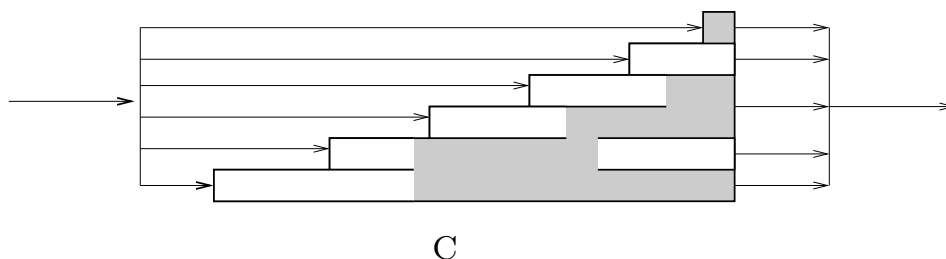
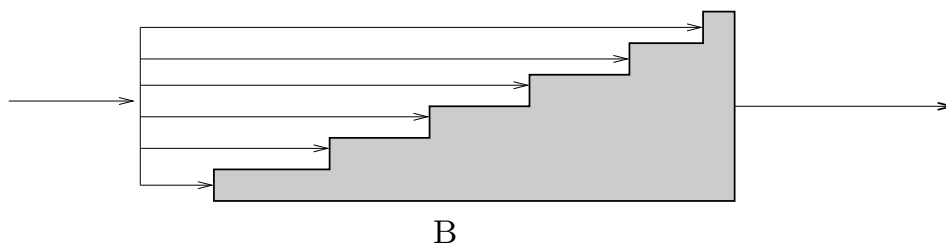
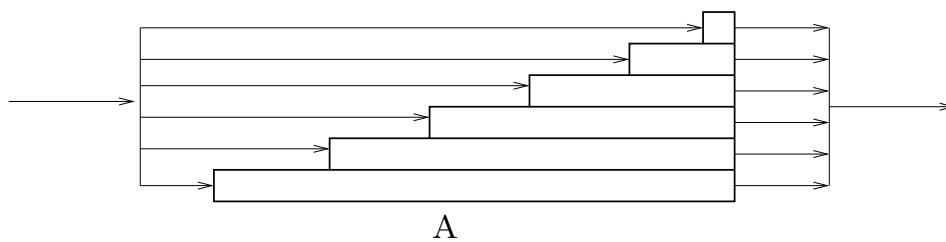

Figure 8.15: Completely segregated flow as a plug-flow reactor with side exits; outlet flows adjusted to achieve given RTD.

As we progress down the plug-flow reactor, the residence time  $\theta$  of the material reaching that location increases. We can imagine withdrawing from the reactor at each location or  $\theta$  a fraction of the flow corresponding to the required RTD value  $p(\theta)$ , although this might be difficult to achieve in practice. A PFR with this removal rate then has the specified RTD. No material in two volume elements with different residence times is ever exchanged because the plug flow has zero backmixing. This last point is perhaps more clear if we redraw the reactor configuration as an equivalent bank of PFRs of different lengths without side exits, as in Figure 8.16.A [19].

# Complete Segregation III



## Complete Segregation IV

Figure 8.16: Alternate representation of completely segregated flow (A), maximum mixed flow (B), and an intermediate mixing pattern (C).

Each tube has a single  $\theta$  value according to its length. We feed the fraction  $p(\theta)$  of the total flow into each tube of residence time  $\theta$  so as to achieve the given RTD for the composite reactor system. This reactor system is called completely segregated because there is no exchange of material between the various tubes. Each tube acts as its own private reactor that processes material for a given amount of time and then discharges it to be mixed with the other reactors at the exit.

It is a simple matter to predict the behavior of this completely segregated reactor. We assume a single reaction and constant density throughout the following discussion. Each tube of specified length or volume  $V$  can be assigned a residence time according to  $\theta = V/Q$ . Let  $c(\theta)$  represent the concentration of a reactant in a volume element that has spent time  $\theta$  in the reactor. Because the reactor is segregated, each tube satisfies the constant density PFR equation, Equation 4.112,

$$\frac{dc}{d\theta} = R(c), \quad c(0) = c_f \quad (8.31)$$

57 / 130

## Complete Segregation V

The concentration of the effluent stream is then simply computed by multiplying the concentration of each tube by the fraction of the total feed passing through that tube

$$c_s = \int_0^{\infty} p(\theta)c(\theta)d\theta \quad (8.32)$$

in which  $c(\theta)$  comes from the solution of Equations 8.31. It is often convenient to remove the explicit integration required by Equation 8.32. Let  $c_s(\theta)$  represent the effect of combining streams with residence times less than or equal to  $\theta$ , so

$$c_s(\theta) = \int_0^{\theta} p(\theta)c(\theta)d\theta$$

From this definition it is clear that  $c_s(\theta)$  satisfies the following differential equation and initial condition

$$\frac{dc_s}{d\theta} = p(\theta)c(\theta), \quad c_s(0) = 0$$

and the reactor effluent concentration is the limit of  $c_s(\theta)$  as  $\theta \rightarrow \infty$ . We can combine the two differential equations for convenient numerical solution of the segregated case

$$\boxed{\begin{array}{ll} \frac{dc}{d\theta} = R(c) & c(0) = c_f \\ \frac{dc_s}{d\theta} = p(\theta)c(\theta) & c_s(0) = 0 \end{array}} \quad (8.33)$$

58 / 130

Notice that this is an initial-value problem, but, in general, we require the solution at  $\theta = \infty$  to determine the effluent concentration of the reactor. Differential equations on semi-infinite domains are termed singular, and require some care in their numerical treatment as we discuss next. On the other hand, if the residence-time distribution is zero beyond some maximum residence time,  $\theta_{\max}$ , then it is straightforward to integrate the initial-value problem on  $0 \leq \theta \leq \theta_{\max}$ .

## Numerical solution. I

We can solve Equation 8.33 as an initial-value problem as written with an ODE solver. Because of the semi-infinite domain, we would need to check the solution for a sequence of increasingly large  $\theta$  values and terminate the ODE solver when the value of  $c_s(\theta)$  stops changing. Alternatively, we can map the semi-infinite domain onto a finite domain and let the ODE solver do the work for us. Many transformations are possible, such as  $z = \exp(-\theta)$ , but experience suggests a strongly decreasing function like the exponential causes the right-hand side to go to infinity at  $z = 1$ , and we simply exchange one singularity for another. A more gentle transformation and its inverse are

$$z = \frac{\theta}{1 + \theta}, \quad \theta = \frac{z}{1 - z}$$

Using this change of variable, we rewrite the derivative as

$$\frac{dc}{d\theta} = \frac{dc}{dz} \frac{dz}{d\theta} = (1 - z)^2 \frac{dc}{dz}$$

Using this result, we transform Equation 8.33 to

$\frac{dc}{dz} = \frac{R(c)}{(1 - z)^2} \quad c(0) = c_f$	(8.34)
$\frac{dc_s}{dz} = \frac{p(z/(1 - z)) c}{(1 - z)^2} \quad c_s(0) = 0$	

Most modern ODE solvers allow the user to specify critical stopping values. These are values of the variable of integration beyond which the ODE solver will not step. We would specify  $z = 1$  as a critical value because the right-hand side is not defined past  $z = 1$ . At the value  $z = 1$ , we would specify the right-hand sides are zero because the reaction will have equilibrated at  $z = 1, \theta = \infty$  so  $R(c) = 0$ , and  $p(\theta) = 0$  at  $\theta = \infty$ . Again, some care with must be taken because the denominators are also going to zero. If the ODE solver terminates successfully, that usually indicates the transformation was successful. It is useful to plot  $c(z)$  to make sure the  $z = 1$  end does not exhibit some unusual behavior.

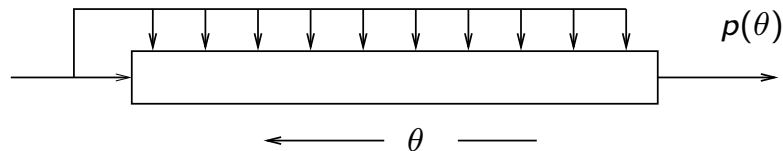

Figure 8.17: Maximum mixed flow as a plug-flow reactor with side entrances; inlet flows adjusted to achieve a given RTD.

## Maximum Mixedness

We realize the opposite mixing limit, maximum mixedness, by reversing the flow in the segregated reactor as shown in Figure 8.17 [21]. The feed stream is distributed along the length of the PFR and injected at the appropriate rate at various side entrances corresponding to different  $\theta$  "locations" to achieve the required RTD. Notice that because the flow has been reversed compared to the segregated case, the  $\theta$  locations increase from zero at the exit of the tube to large values at the entrance to the tube. We allow an infinitely long tube if we wish to allow RTDs such as the CSTR defined on a semi-infinite domain. Reactors with these specified sidestream addition policies are conceptually important in understanding recent research on achievable reactor performance as discussed in Section 8.4.

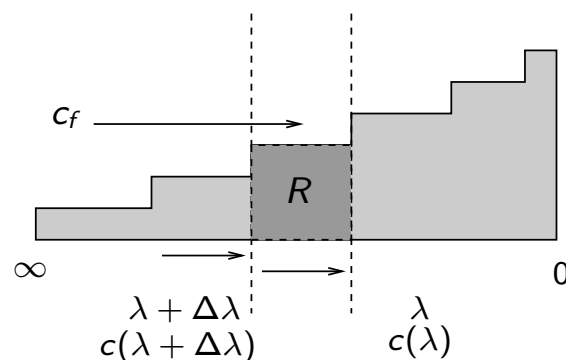

Figure 8.18: Volume element in the state of maximum mixedness.

## Numerical solution. I

We wish to transform the  $\lambda \in (\infty, 0)$  interval into  $z \in (0, 1)$ . The analogous transformation to the segregated reactor is

$$z = \frac{1}{1 + \lambda}, \quad \lambda = \frac{1 - z}{z}$$

The derivative becomes

$$\frac{dc}{d\lambda} = \frac{dc}{dz} \frac{dz}{d\lambda} = -z^2 \frac{dc}{dz}$$

in which the minus sign arises because we are changing the direction when integrating in the transformed  $z$  variable. Equation 8.35 then becomes

$$\boxed{\frac{dc}{dz} = -\frac{1}{z^2} \left[ \frac{p((1-z)/z)}{1 - P((1-z)/z)} (c - c_f) - R(c) \right] \quad c(0) = c_\infty} \quad (8.36)$$

and we integrate from  $z = 0$  to  $z = 1$ . Again, a critical stopping value should be set at  $z = 1$  to avoid an undefined right-hand side. We set the right-hand side to zero at  $z = 0$  because we determined the value of  $c_\infty$  such that the bracketed term in Equation 8.36 was zero. Again, care should be exercised at  $z = 0$  because the denominator goes to zero at  $z = 0 (\lambda = \infty)$ . Plotting  $c(z)$  and examining the  $z = 0$  end for unusual behavior is recommended.

63 / 130

## Numerical solution. II

### Example 8.3: Two CSTRs in series

We illustrate the results of these sections with an example taken from Zwietering [21]. Given the RTD of two equal-sized CSTRs in series for a single, second-order, irreversible reaction, compute the reactor effluent concentration for the following cases: segregated flow, maximum mixedness and two ideal CSTRs.

### Solution

The residence-time distribution for two CSTRs in series is given by Equations 8.16 and 8.20 for  $n = 2$ ,

$$p(\theta) = \frac{4\theta}{\tau^2} e^{-2\theta/\tau}$$
$$1 - P(\theta) = (1 + 2\theta/\tau) e^{-2\theta/\tau}$$

in which  $\tau = V_R/Q_f$  and  $V_R$  is the total volume of the CSTRs. The balance for the maximum mixedness case becomes

$$\frac{dc}{d\lambda} = \frac{4\lambda}{\tau(\tau + 2\lambda)} (c - c_f) + kc^2$$

64 / 130



## Numerical solution. III

Defining dimensionless variables,  $\bar{c} = c/c_0$  and  $\bar{\lambda} = \lambda/\tau$ , the equation becomes

$$\frac{d\bar{c}}{d\bar{\lambda}} = \frac{4\bar{\lambda}}{2\bar{\lambda} + 1}(\bar{c} - 1) + K\bar{c}^2$$

in which  $K = k_{C_0}\tau$ . Notice that all the physical constants of the reactor combine into the single dimensionless constant  $K$ . If we apply the zero slope condition at  $\lambda = \infty$ , we obtain the quadratic equation

$$2(\bar{c}_\infty - 1) + K\bar{c}_\infty^2 = 0$$

which can be solved for  $\bar{c}_\infty$ . Again we have an equation on a semi-infinite interval, which we can transform via

$$z = \frac{1}{1 + \bar{\lambda}}, \quad \bar{\lambda} = \frac{1 - z}{z}$$

in which  $\bar{\lambda} \in (\infty, 0)$  is transformed to  $z \in (0, 1)$ . The transformed derivative satisfies

$$\frac{d\bar{c}}{d\bar{\lambda}} = \frac{d\bar{c}}{dz} \frac{dz}{d\bar{\lambda}} = -z^2 \frac{d\bar{c}}{dz}$$

65 / 130

## Numerical solution. IV

so the final differential equation is

$$\frac{d\bar{c}}{dz} = -\frac{1}{z^2} \left[ \frac{4(1-z)/z}{2(1-z)/z + 1} (\bar{c} - 1) + K\bar{c}^2 \right]$$
$$\bar{c}(0) = \bar{c}_\infty$$

The effluent of the maximum mixed reactor is given by the solution  $\bar{c}(z)$  at  $z = 1$ . Figure 8.19 displays the solution to this differential equation for a range of  $K$  values.

66 / 130

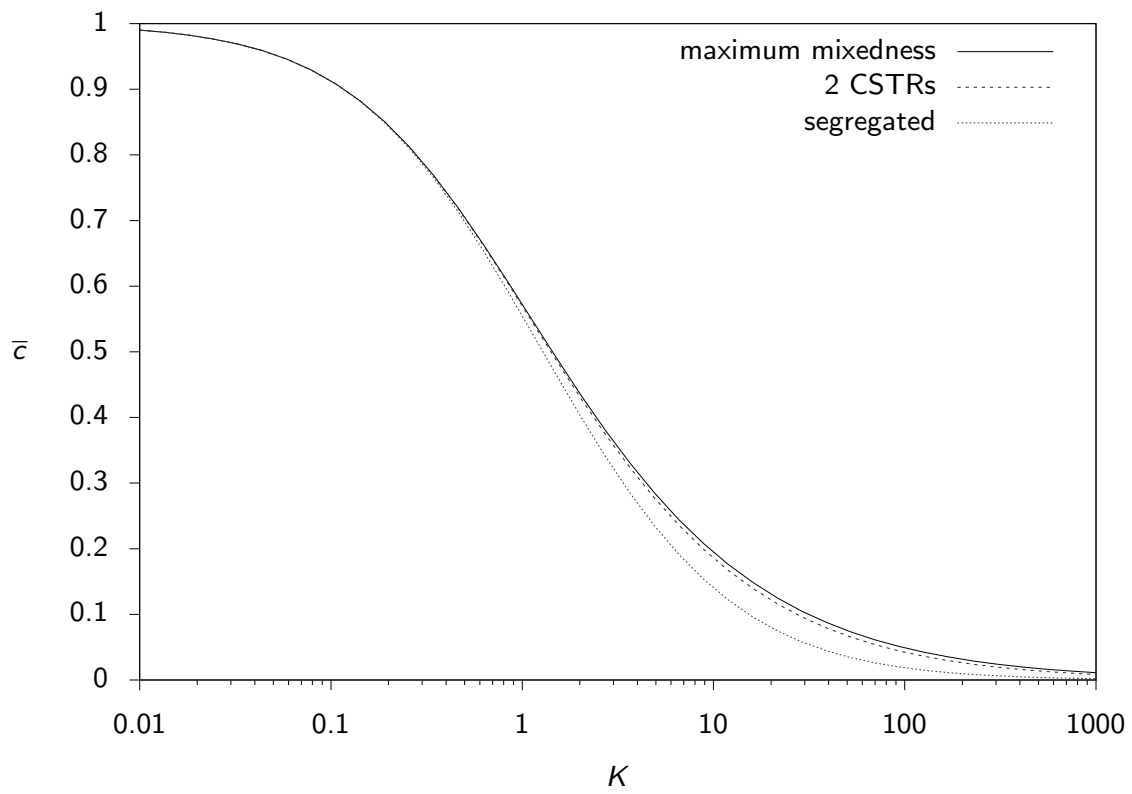

Figure 8.19: Dimensionless effluent concentration  $\bar{c} = c/c_0$  versus dimensionless rate constant  $K = k\tau c_0$  for second-order reaction; the RTD for all cases is given by 2 CSTRs in series.

□

Weinstein and Adler [19] also proposed an interesting general conceptual mixing model by allowing a general mixing pattern between the various tubes as depicted in Figure 8.16.C. The segregated reactor depicted in Figure 8.15 and Figure 8.16.A is sometimes referred to as late mixing or mixing as late as possible. The material remains segregated until it reaches the common exit where the segregated streams are finally mixed in the reactor effluent. The situation depicted by the maximum mixedness reactor of Figure 8.17 and Figure 8.16.B is sometimes called early mixing. The material is mixed at the earliest possible times as it travels down the tubes; no segregated streams remain to be combined at the reactor exit.

Consider again the two reactors in Example 8.2. The conceptual mixing pattern is sketched in Figure 8.20.

## Intermediate conditions of mixing. II

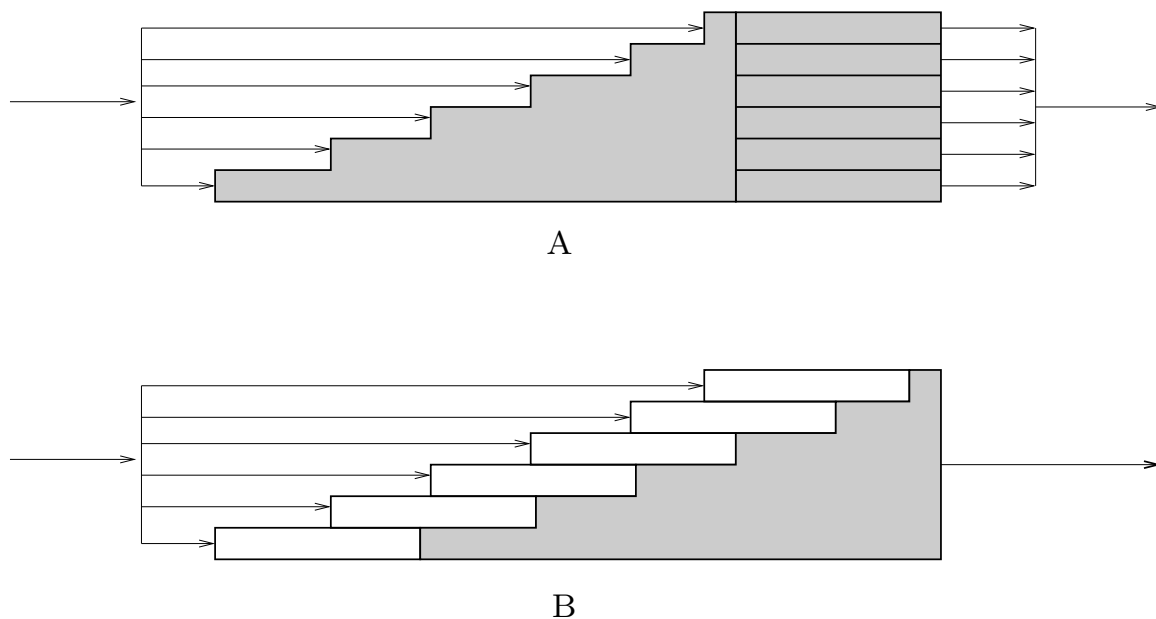
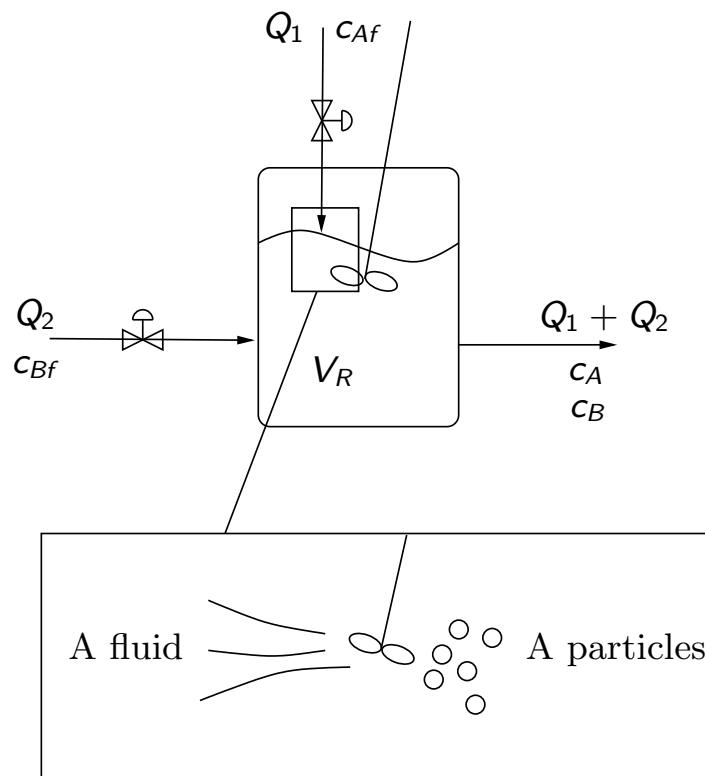

**Figure 8.20:** CSTR followed by PFR (A) and PFR followed by CSTR (B) as examples of complete and partial mixing; RTDs for the two configurations are equal.

The reactors have identical RTDs. Comparing these two reactor configurations, the reactor with the CSTR preceding the PFR is in the condition of maximum mixedness because the CSTR is the condition of maximum mixedness and the feed to the PFR is therefore well mixed, so the different portions of the RTD in the PFR section have identical compositions, and could be considered well mixed or segregated. The PFR preceding the CSTR is not in the condition of maximum mixedness, nor is it segregated. As shown in Figure 8.20, it displays an intermediate state of mixing, similar to case C in Figure 8.16. We show in Section 8.4 that because the reaction rate is second order, complete mixing gives the lowest conversion possible consistent with the given RTD. This conclusion is consistent with the calculation performed in Example 8.2 in which the CSTR–PFR arrangement had lower conversion than the PFR–CSTR.

71 / 130

## Mass Transfer and Limits of Reactor Mixing



**Figure 8.21:** Adding two liquid-phase feed streams to a stirred tank; the stirrer is modeled as shearing the liquid A feed stream into small, uniformly sized particles of A and randomly distributing them in the continuous phase containing B.

72 / 130

## A Single Convex (Concave) Reaction Rate I

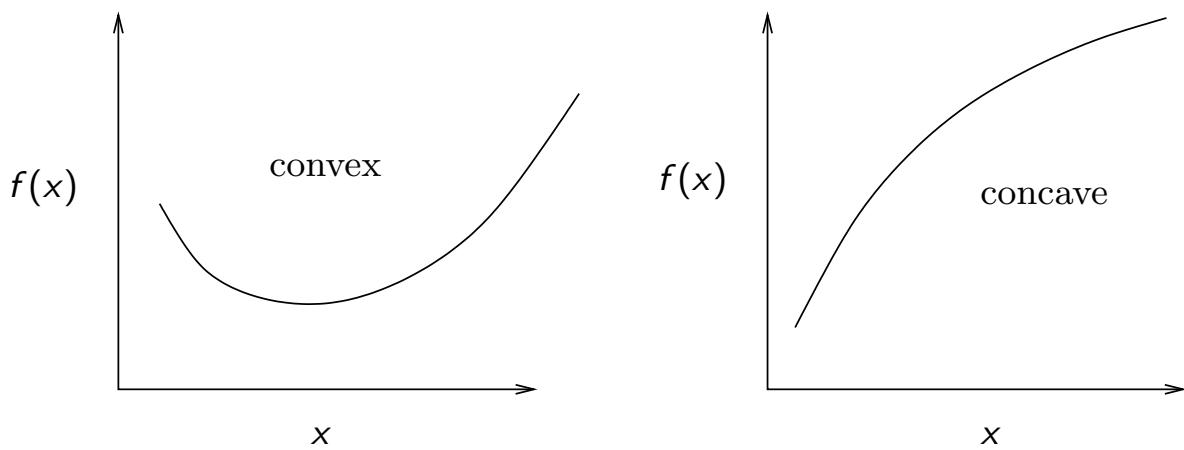

Figure 8.24: Differentiable convex and concave functions.

## A Single Convex (Concave) Reaction Rate II

To generalize the results of Examples 8.2 and 8.3, we define convex and concave functions. As presented in the introductory calculus course, the simplest version pertains to functions having at least two derivatives. In that case, a function is convex (concave upward) if its second derivative is everywhere greater than or equal to zero. A function is concave (concave downward) if its second derivative is everywhere less than or equal to zero, as shown in Figure 8.24

$$\frac{d^2 f(x)}{dx^2} \geq 0, \quad f \text{ convex}$$
$$\frac{d^2 f(x)}{dx^2} \leq 0, \quad f \text{ concave}$$

For example, the  $n$ th-order reaction-rate expression  $r = c^n$ , is *convex* if  $n \geq 1$  and *concave* if  $n \leq 1$ . Note that first-order rate functions are both convex and concave. The general result for the single reaction is

Given a single reaction with convex (concave) reaction rate expression, the highest (lowest) conversion for a given RTD is achieved by the segregated reactor and the lowest (highest) conversion is achieved by the maximally mixed reactor.

75 / 130

## A Single Convex (Concave) Reaction Rate III

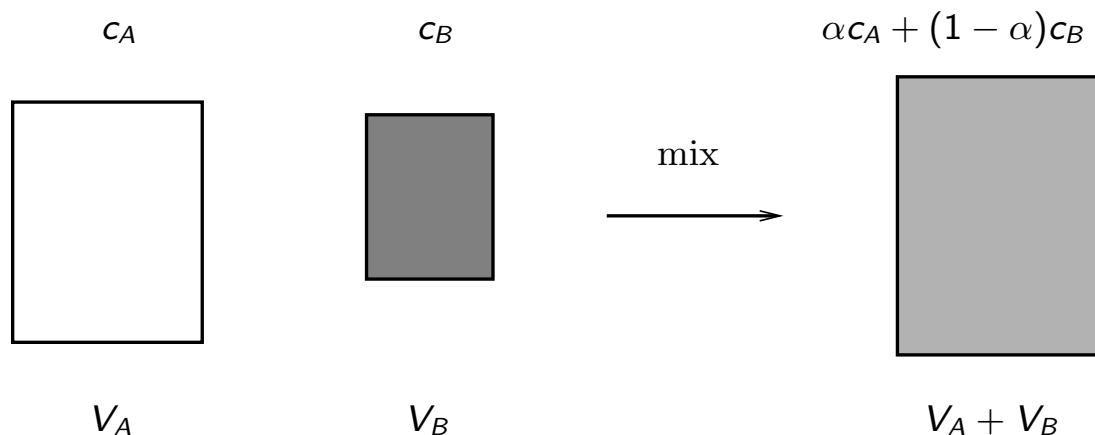

Figure 8.25: Two volume elements before and after mixing.

This nonobvious result is a significant generalization of the numerical Examples 8.2 and 8.3, and Exercise 8.6, and requires justification. The argument presented next first appeared in Chauhan et al. [3]; Nauman and Buffham [15] also provide a detailed discussion.

76 / 130

## Step 1. I

To start, consider the two volume elements shown in Figure 8.25. Note that in this discussion  $c_A$  and  $c_B$  represent concentration of the *same reactant species* in volume elements or tubes A and B. When the volume elements are segregated the total reaction rate  $r_s$  is simply

$$r_s = r(c_A)V_A + r(c_B)V_B$$

so that the segregated rate per volume is

$$r_s = \alpha r(c_A) + (1 - \alpha)r(c_B), \quad 0 \leq \alpha \leq 1$$

in which  $\alpha$  is the volume fraction of element A

$$\alpha = \frac{V_A}{V_A + V_B}$$

On the other hand, if we mix the contents, the concentration is

$$c_m = \frac{c_A V_A + c_B V_B}{V_A + V_B} = \alpha c_A + (1 - \alpha)c_B$$

The total reaction rate per volume after mixing is therefore

$$r_m = r(c_m)$$

77 / 130

## Step 1. II

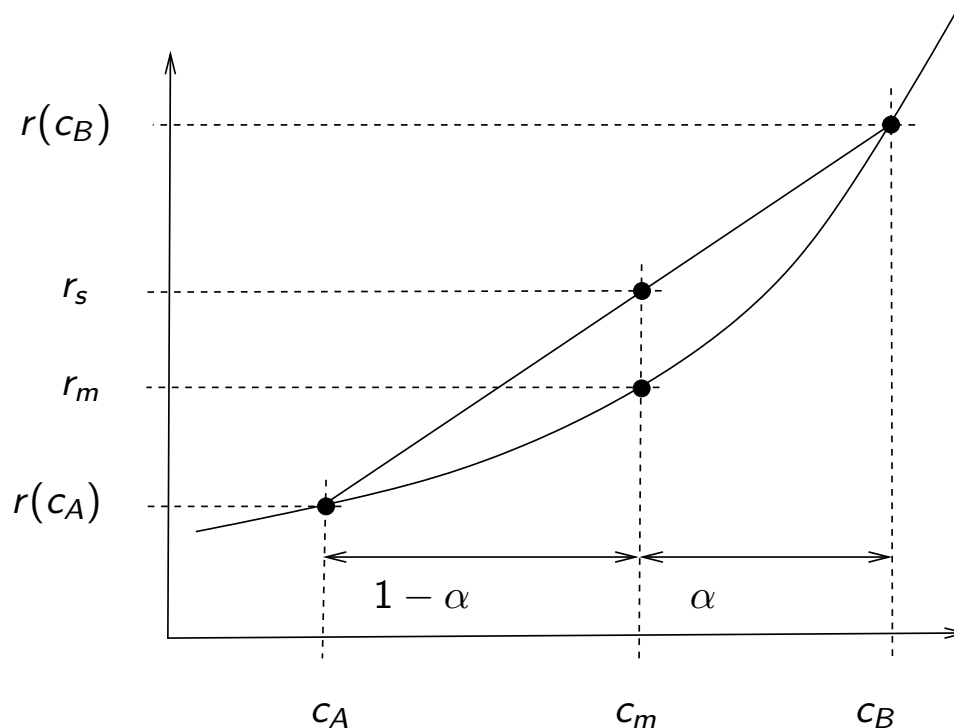

Figure 8.26: Convex rate expression and the effect of mixing; rate of the mean ( $r_m$ ) is less than the mean of the rate ( $r_s$ ).

78 / 130

## Step 1. III

As shown in Figure 8.26, for all  $c_A$ ,  $c_B$  and  $\alpha$ , if we mix the two volume elements, we lower the overall reaction rate. The opposite conclusion applies if we have a concave rate expression. The rate of the mean  $r_m$  is less than the mean of the rate  $r_s$  for convex reactions, or

$$r(\alpha c_A + (1 - \alpha)c_B) \leq \alpha r(c_A) + (1 - \alpha)r(c_B), \quad \text{all } c_A, c_B, 0 \leq \alpha \leq 1$$

This result is the key to understanding what happens in the general reactor. In fact, this statement can be taken as the definition of convexity (Exercise 8.13).

79 / 130

## Step 2. I

Now consider two tubes as shown in Figure 8.27, which we may choose to mix or maintain segregated as material proceeds down their lengths.

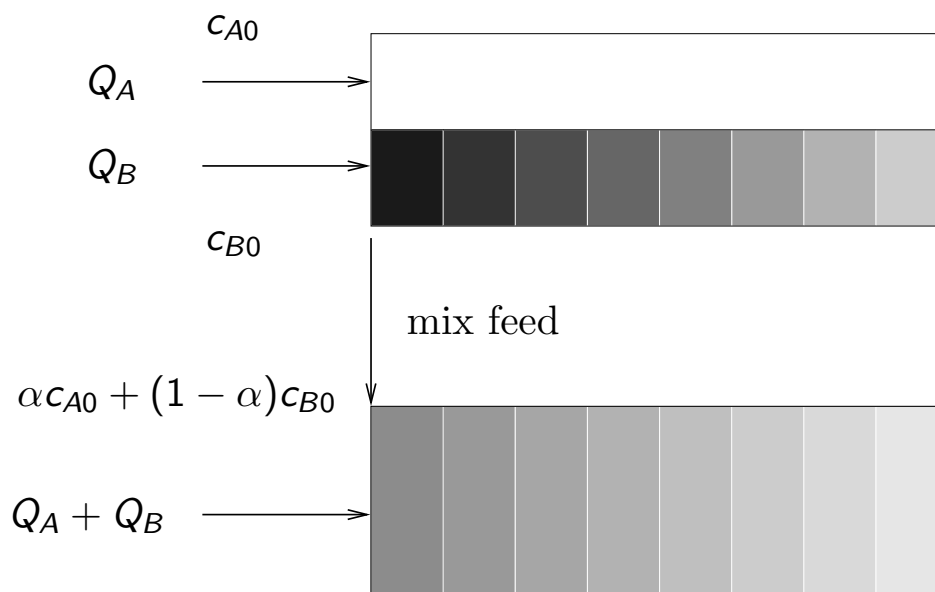

Figure 8.27: Two tubes before and after mixing the entering feed; averaging the two segregated tubes produces  $c_s$ ; the mixed feed tube produces  $c_m$ .

80 / 130



## Step 2. II

Again assume a single reaction takes place and the reaction-rate expression is a convex function of a single reactant species. Without loss of generality assume the stoichiometric coefficient for the limiting species is negative one. For constant density, the material balances for the segregated tubes are

$$\begin{aligned}\frac{dc_A}{d\theta} &= -r(c_A), & c_A(0) &= c_{A0} \\ \frac{dc_B}{d\theta} &= -r(c_B), & c_B(0) &= c_{B0}\end{aligned}$$

in which  $\theta = V/Q_f$ . We can track the mean concentration for the segregated case  $c_s$  by simply summing the molar flows for tubes A and B divided by the total flow

$$c_s = \alpha c_A + (1 - \alpha)c_B \quad (8.39)$$

in which  $\alpha$  is now the flowrate fraction in tube A

$$\alpha = \frac{Q_A}{Q_A + Q_B}$$

We also can write a differential equation for  $c_s$  by simply differentiating Equation 8.39

$$\frac{dc_s}{d\theta} = -[\alpha r(c_A) + (1 - \alpha)r(c_B)], \quad c_s(0) = \alpha c_{A0} + (1 - \alpha)c_{B0} \quad (8.40)$$

81 / 130

## Step 2. III

Consider now the mixed case. If the tubes are mixed at some point, which we may call  $\theta = 0$ , then the material balance for the concentration after that point is

$$\frac{dc_m}{d\theta} = -r(c_m), \quad c_m(0) = \alpha c_{A0} + (1 - \alpha)c_{B0} \quad (8.41)$$

Our goal now is to show  $c_m \geq c_s$  for all reactor positions,  $\theta$ , and all feed concentrations and flowrates,  $c_{A0}$ ,  $c_{B0}$  and  $\alpha$ . We know at  $\theta = 0$

$$\frac{dc_m}{d\theta} = -[r(\alpha c_{A0} + (1 - \alpha)c_{B0})] \geq -[\alpha r(c_A) + (1 - \alpha)r(c_B)] = \frac{dc_s}{d\theta}$$

If the initial derivatives have this relationship we know, for at least some small distance down the tube,  $c_m \geq c_s$  as shown in Figure 8.28.

82 / 130

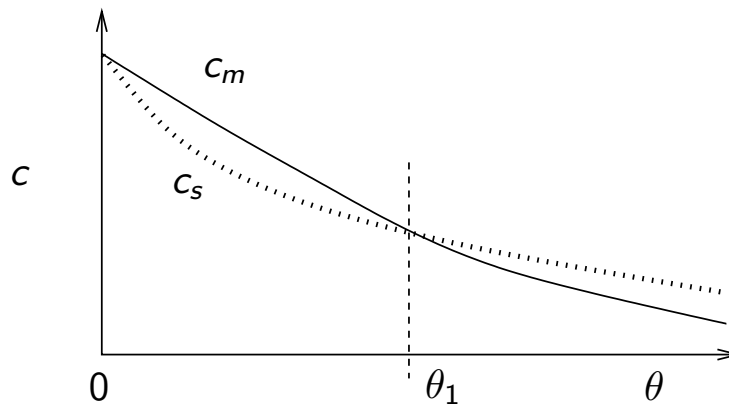

Figure 8.28: Mean segregated and mixed concentrations versus  $\theta$ ; curves crossing at  $\theta_1$  is a contradiction.

## Step 2. V

How do we know, however, that the curves do not cross each other at some later time? Assume this crossing can happen as shown in Figure 8.28, and we establish a contradiction. Let  $\theta_1$  be the first such crossing time. At  $\theta_1$ ,  $c_A$  and  $c_B$  have some well-defined values and  $c_s = \alpha c_A + (1 - \alpha)c_B$ . We have assumed that  $c_m = c_s$  at  $\theta_1$  so the differential equation for  $c_m$ , Equation 8.41, gives

$$\frac{dc_m}{d\theta} = -[r(\alpha c_A + (1 - \alpha)c_B)], \quad \theta = \theta_1$$

The differential equation for  $c_s$  still applies and Equation 8.40 gives

$$\frac{dc_s}{d\theta} = -[\alpha r(c_A) + (1 - \alpha)r(c_B)], \quad \theta = \theta_1$$

Comparing the right-hand sides of these two differential equations and using the convexity of  $r(c)$ , we conclude

$$\frac{dc_m}{d\theta} \geq \frac{dc_s}{d\theta}, \quad \theta = \theta_1$$

But this relationship contradicts the assumption that the  $c_s$  and  $c_m$  curves cross each other. Therefore there can be no time  $\theta_1$  at which the curves cross and we conclude

$$c_m(\theta) \geq c_s(\theta), \quad \text{all } \theta$$

This argument and result apply equally well for all  $c_{A0}$ ,  $c_{B0}$  and  $\alpha$ .

Finally, consider a segregated reactor with arbitrary residence-time distribution as depicted in Figure 8.16.C. We select any pair of tubes, mix them, make the same argument that we made in Step 2, and replace the segregated tubes with mixed tubes that achieve lower conversion than the original system. We continue in this fashion, and after we pairwise mix all the segregated tubes with mixed tubes, we achieve the reactor of maximum mixedness in Figure 8.16.B. and the lowest possible conversion. Note this pairing and mixing procedure does not affect the RTD.

## The General Case I

One might expect that the limits of reactor mixing determine directly the limits of reactor performance for more general kinetic schemes as well as the single convex or concave rate expression of the last section. Unfortunately nature is more subtle. We present next an example that dispels this notion, and then discuss what is known about the limits of reactor performance. This example is based on one presented by Glasser, Hildebrandt and Godorr [8]. Levenspiel [14] shows how to find the optimal reactor configuration for this type of example.

### **Example 8.4: Optimal is neither segregated nor maximally mixed**

Consider the rate expression

$$r(c) = \frac{c}{1 + 5c^2} + 0.05c \quad (8.42)$$

which is plotted in Figure 8.29.

## The General Case II

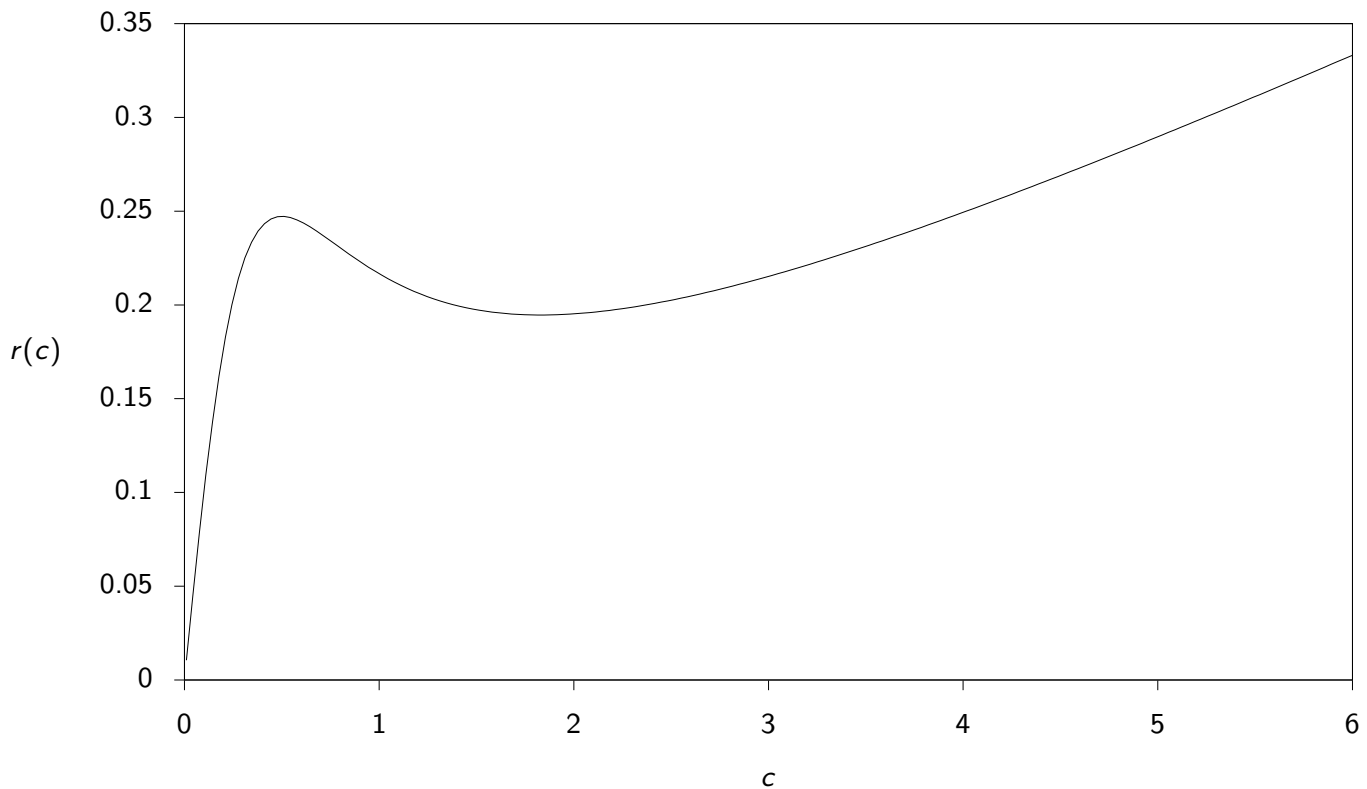

87 / 130

## The General Case III

**Figure 8.29:** Reaction rate versus concentration of limiting reactant; rate expression is neither convex nor concave.

For a feed concentration of 5, find the combination of CSTRs and PFRs that achieve 95% conversion with the smallest total reactor volume. Determine the RTD for this reactor configuration. What conversion is achieved in a segregated reactor with this RTD? What conversion is achieved in a maximally mixed reactor with this RTD?

### Solution

As we mentioned in Chapter 4, the smallest volume can be achieved with a series combination of CSTRs and PFRs. First we plot the inverse of the rate as shown in Figure 8.30.

88 / 130

## The General Case IV

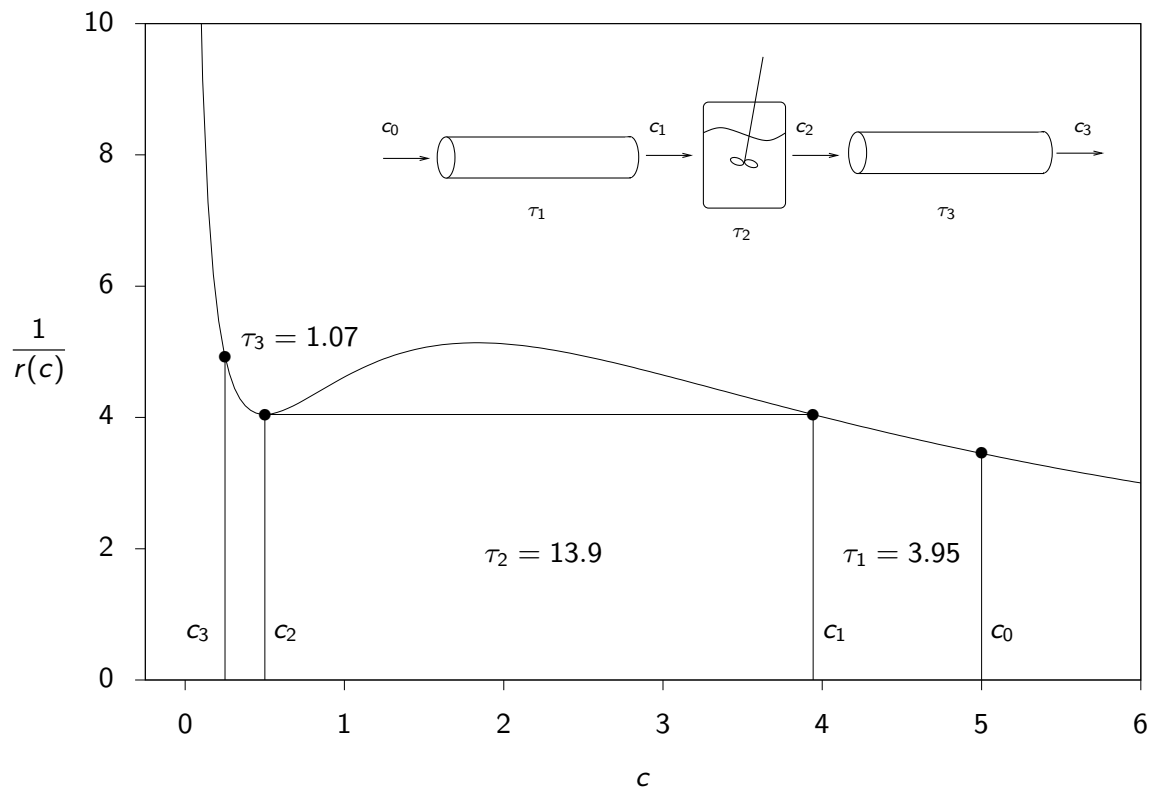

89 / 130

## The General Case V

**Figure 8.30:** Inverse of reaction rate versus concentration; optimal sequence to achieve 95% conversion is PFR–CSTR–PFR.

Then we find any minima in the inverse rate function and construct CSTRs from those values until we intersect the inverse rate curve. In the remaining sections of the curve where the inverse rate is a decreasing function of concentration, we use PFRs. Examining the plotted  $1/r$  function in Figure 8.30, we see the optimal configuration is a PFR–CSTR–PFR; this configuration is sketched in Figure 8.30. We can calculate the sizes of the reactors as follows. We know from the problem statement that  $c_0 = 5, c_3 = 0.25$ . We next find the point where  $dr(c)/dc = 0$ . Notice these are also the places where  $d(1/r(c))/dc = 0$ . Setting the derivative of Equation 8.42 to zero gives a quadratic equation with two roots: 0.501 and 1.83. We choose the one corresponding to the minimum in  $1/r$ , which gives

$$c_2 = 0.501, \quad 1/r(c_2) = 4.045$$

90 / 130

## The General Case VI

Next we find the concentration  $c_1$  such that  $1/r(c_1) = 1/r(c_2)$ . This results in a cubic equation, which we solve numerically. Then the residence time is given by  $\theta_2 = 1/r(c_2)(c_1 - c_2)$  which gives

$$c_1 = 3.94, \quad \theta_2 = 13.9$$

To size the PFRs we simply use the PFR design equation and obtain

$$\theta_1 = - \int_{c_0}^{c_1} \frac{1}{r(c)} dc = 3.95, \quad \theta_3 = - \int_{c_2}^{c_3} \frac{1}{r(c)} dc = 1.07$$

These results are displayed in Figure 8.30. Because we have a series of CSTRs and PFRs, we can write the RTD immediately

$$p(\theta) = \frac{1}{\theta_2} \exp \left[ -\frac{\theta - (\theta_1 + \theta_3)}{\theta_2} \right] H(\theta - (\theta_1 + \theta_3))$$

which is plotted in Figure 8.31.

91 / 130

## The General Case VII

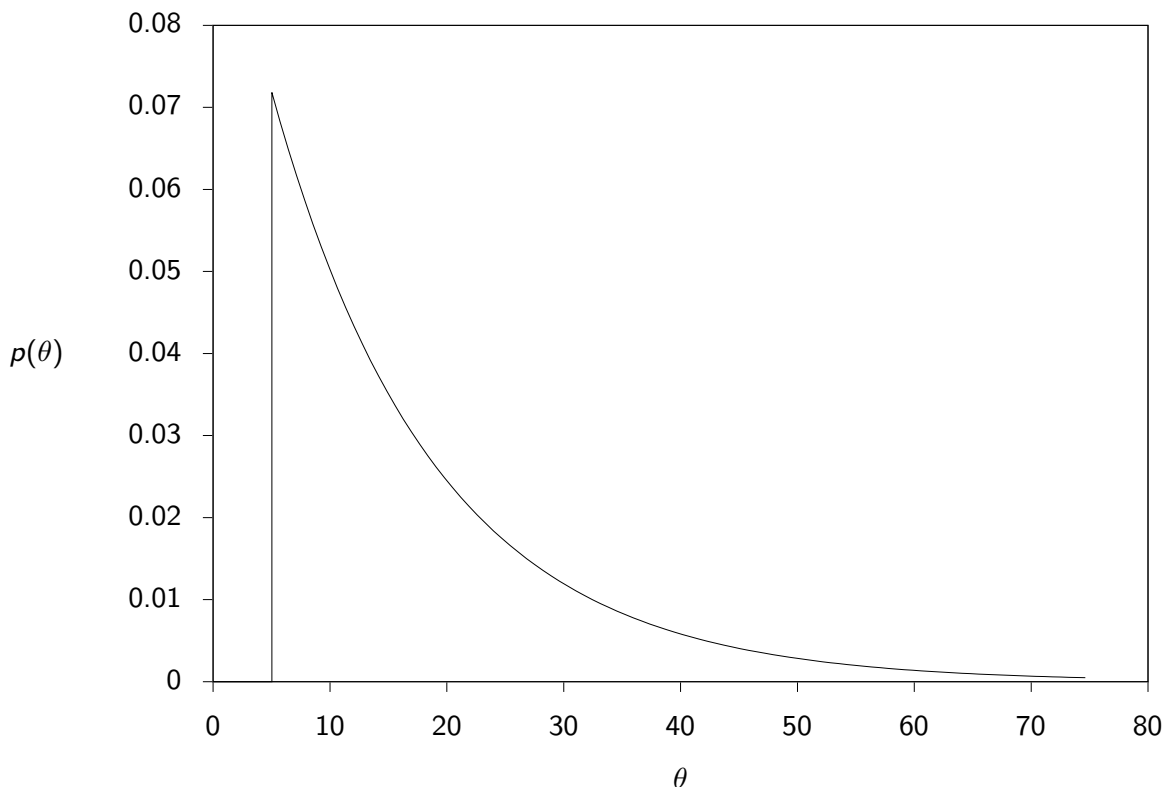

Figure 8.31: Residence-time distribution for the optimal reactor configuration.

## The attainable region. I

The primary use of the classical mixing models, such as the segregated reactor and the maximally mixed reactor, is to build insight into the effects of mixing on reactor behavior under the constraint of a fixed, and presumably measurable, RTD. As we have seen in Example 8.4, however, if we are mainly interested in determining bounds on achievable reactor states (conversions, yields, etc.), these simple mixing models are insufficient. In this section we would like to provide a brief overview of what is known about finding sharp bounds on reactor performance. The general problem can be defined in this way.

*Given a feed stream of known composition and a set of chemical reactions with known rate expressions, determine the set of all possible steady-state species concentrations that can be achieved by any combination of chemical reactors.*

This set was proposed by Horn almost 40 years ago and named the **attainable region** [10]. Because the set is defined for *all possible reactor combinations*, it seems conceptually difficult to formulate a procedure by which we can calculate this set. We should also note that by considering all reactor combinations, we are also considering all possible residence-time distributions, which is a considerable generalization from the single RTD that was considered in the mixing discussion in previous sections. In spite of the seeming difficulty in finding the attainable region, excellent, recent research progress has been made. Feinberg provides a nice summary overview of the history and many recent developments [5].

93 / 130

## The attainable region. II

Glasser and Hildebrandt revived recent interest in this problem [9, 8]. Feinberg and Hildebrandt [7] characterized the boundary of the attainable region, which is of importance because it bounds the possible steady-state concentrations. They showed, for example, that the extreme points of the attainable region boundary are made up entirely of plug-flow reactor trajectories. They also showed that combinations of PFRs, CSTRs, and what are called differential side-stream reactors (PFRs with addition of feed along the side of the tube), provide the means to find all of the attainable region extreme points. In addition to properties and conceptual characterization of the attainable region, researchers have proposed computational procedures to approximate the attainable region and solve reactor synthesis problems. Some of these are based on proposing a superstructure of reactor types and numbers, and optimizing an objective function among the possible reactors [11]. Because the superstructure does not enumerate all possibilities, the solution may not be close to the true attainable region. A person skilled in reactor design may be able to choose reactor numbers and types well and overcome this general difficulty on specific reaction networks of interest.

Some computational methods are based on finding the boundary of the attainable region using the reactor types that characterize the attainable region extreme points. Hybrid methods involving superstructures and geometric considerations have also been proposed [12].

94 / 130

Manousiouthakis has recently proposed an infinite dimensional state-space approach (IDEAS) that requires only PFRs, CSTRs and mixing. The advantage of this approach is that one solves only convex, linear optimization problems. The disadvantage is the problems are infinite dimensional and require a finite dimensional approximation for calculation. A full analysis of the convergence properties of the finite dimensional approximation is not yet available, but the approach shows promise on numerical examples [2].

If we wish to allow separation as well as chemical reaction, and almost all industrial designs would fall into this category, then the problem switches from a pure reactor synthesis problem to a reactor-separator synthesis problem. The CSTR equivalence principle of Chapter 4 is an example of the strikingly simple and general results that recently have been achieved for the reactor-separator synthesis problem [6].

Forecasting is always risky business, but given the rapid pace of recent progress, it seems likely that new and highly useful results on pure reactor and reactor-separator synthesis problems will be forthcoming. These ideas and results may have immediate industrial impact, and certainly fall within the scope of the course in reactor analysis and design.

## Examples in Which Mixing is Critical

Returning to the topic of mixing, we would like to close the chapter by presenting a few more chemical mechanisms for which reactor mixing can play a critical role.



## Example 8.5: Mixing two liquid-phase streams in a stirred tank

- A classic mixing problem arises when we must bring two liquid-phase feed streams together to perform the second-order reaction

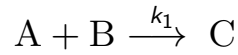

in the presence of the undesirable side reaction

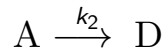

- If the rate of the second degradation reaction is fast compared to the rate of mixing of the two feed streams, we can anticipate problems. To understand what happens in this situation, consider the mixing model depicted in Figure 8.32.

□

97 / 130

## A simple mixing model

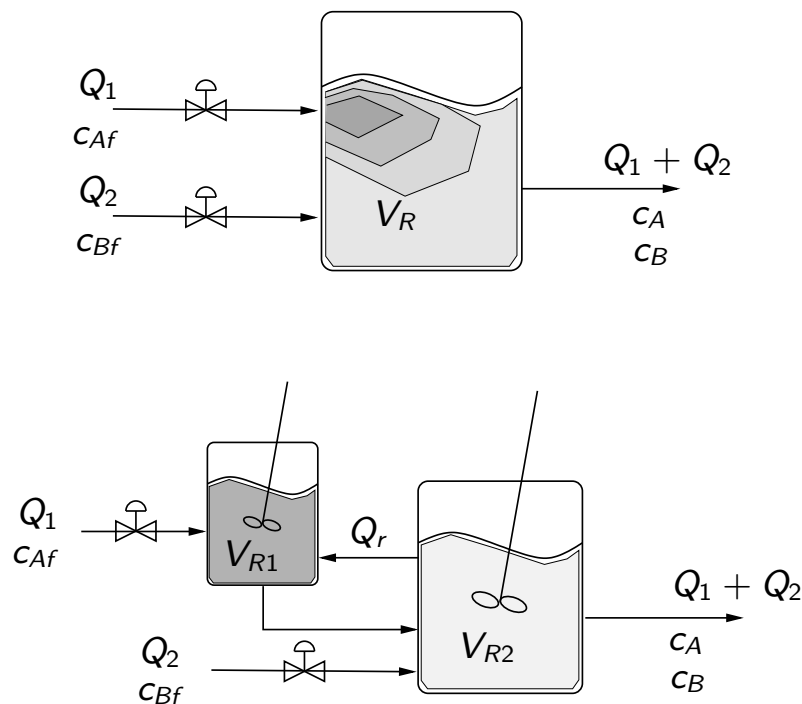

Figure 8.32: Imperfect mixing (top reactor) leads to formation of an A-rich zone, which is modeled as a small CSTR feeding a second CSTR (bottom two reactors).

98 / 130

- Component A is assumed to be the limiting reactant. It is added at a low flowrate to a CSTR that contains an excess of reactant B.
- In the top figure we depict the ideal-mixing case in which the rate of mixing is arbitrarily fast compared to the rate of either reaction. But this ideal mixing may be impossible to achieve if the reaction rates are reasonably large.
- So in the bottom figure, we model the formation of an A-rich zone near the feed entry point. This small CSTR exchanges mass with a larger reactor that contains the excess of reactant B.
- We can vary the recycle flowrate between the two CSTRs,  $Q_r$ , to vary the degree of mixing. For large  $Q_r$ , we expect the two-reactor mixing model to approach the single, ideally mixed CSTR.

## Conversion and yield

- As discussed in Chapter 4, the conversion and yield are the usual quantities of interest in competing parallel reactions of the type given in Reactions 8.43 and 8.44.
- We assume the density of this liquid-phase system is constant, and define the overall conversion of reactant A and yield of desired product C as follows:

$$x_A = \frac{Q_1 c_{Af} - (Q_1 + Q_2) c_A}{Q_1 c_{Af}} \quad y_C = \frac{(Q_1 + Q_2) c_C}{Q_1 c_{Af} - (Q_1 + Q_2) c_A}$$

- Given the parameters and rate constants in Table 8.3, calculate  $x_A$  and  $y_C$  versus  $Q_r$  for the two-reactor mixing model shown in Figure 8.32, and compare the result to the single, well-mixed reactor.
- Then calculate the residence-time distribution  $P(\theta)$  for tracer injected with the A feed stream for the two models. Discuss whether or not the residence-time distribution is a reliable indicator for problems with yield in the imperfectly mixed reactor.

## Problem parameters

Parameter	Value	Units
$k_1$	1	$\text{min}^{-1}$
$k_2$	2	$\text{L/mol}\cdot\text{min}$
$n$	2	
$\theta_1 = V_{R1}/Q_2$	1	min
$\theta_2 = V_{R2}/Q_2$	2	min
$\theta = V_R/Q_2$ $= \theta_1 + \theta_2$	3	min
$\alpha = Q_1/Q_2$	0.1	
$\rho = Q_r/Q_2$	varies	

Table 8.3: Reactor and kinetic parameters for feed-mixing example.

The steady-state mass balance for the single, well-mixed CSTR is

$$\begin{aligned} 0 &= Q_1 c_{Af} - (Q_1 + Q_2) c_A - (k_1 c_A c_B + k_2 c_A^n) V_R \\ 0 &= Q_2 c_{Bf} - (Q_1 + Q_2) c_B - k_1 c_A c_B V_R \end{aligned}$$

Defining the following parameters

$$\alpha = \frac{Q_1}{Q_2} \quad \theta = \frac{V_R}{Q_2} \quad \rho = \frac{Q_f}{Q_2}$$

allows us to write these as

$$\begin{aligned} 0 &= \alpha c_{Af} - (1 + \alpha) c_A - (k_1 c_A c_B + k_2 c_A^n) \theta \\ 0 &= c_{Bf} - (1 + \alpha) c_B - k_1 c_A c_B \theta \end{aligned}$$

## Single-reactor model

We can solve numerically the two equations for the two unknowns  $c_A, c_B$ .  
The concentration of C in the outflow is determined from the change in the concentration of B,

$$(Q_1 + Q_2) c_C = Q_2 c_{Bf} - (Q_1 + Q_2) c_B$$

Using this relationship and the defined parameters gives for conversion and yield,

$$x_A = \frac{\alpha c_{Af} - (1 + \alpha) c_A}{\alpha c_{Af}} \quad y_C = \frac{c_{Bf} - (1 + \alpha) c_B}{\alpha c_{Af} - (1 + \alpha) c_A}$$

For the two-reactor system, we write mass balances for each reactor. Let  $c_{A1}$ ,  $c_{A2}$ ,  $c_{B1}$ ,  $c_{B2}$  be the unknown A and B concentrations in the two-reactors, respectively.

The mass balances are

Reactor 1:

$$0 = Q_1 c_{Af} - (Q_1 + Q_r) c_{A1} + Q_r c_{A2} - (k_1 c_{A1} c_{B1} + k_2 c_{A1}^2) V_{R1}$$

$$0 = -(Q_1 + Q_r) c_{B1} + Q_r c_{B2} - k_1 c_{A1} c_{B1} V_{R1}$$

Reactor 2:

$$0 = (Q_1 + Q_r) c_{A1} - Q_r c_{A2} - (Q_1 + Q_2) c_{A2} - (k_1 c_{A2} c_{B2} + k_2 c_{A2}^2) V_{R2}$$

$$0 = Q_2 c_{Bf} + (Q_1 + Q_r) c_{B1} - Q_r c_{B2} - (Q_1 + Q_2) c_{B2} - (k_1 c_{A2} c_{B2}) V_{R2}$$

## Two-reactor model

We can summarize this case using the previously defined variables as four equations in four unknowns

$$0 = \alpha c_{Af} - (\alpha + \rho) c_{A1} + \rho c_{A2} - (k_1 c_{A1} c_{B1} + k_2 c_{A1}^2) \theta_1$$

$$0 = -(\alpha + \rho) c_{B1} + \rho c_{B2} - k_1 c_{A1} c_{B1} \theta_1$$

$$0 = (\alpha + \rho) c_{A1} - \rho c_{A2} - (1 + \alpha) c_{A2} - (k_1 c_{A2} c_{B2} + k_2 c_{A2}^2) \theta_2$$

$$0 = c_{Bf} + (\alpha + \rho) c_{B1} - \rho c_{B2} - (1 + \alpha) c_{B2} - (k_1 c_{A2} c_{B2}) \theta_2$$

- The conversion is not adversely affected by the poor mixing. In fact, the conversion in the two-reactor system is higher than the single, well-mixed reactor.

107 / 130

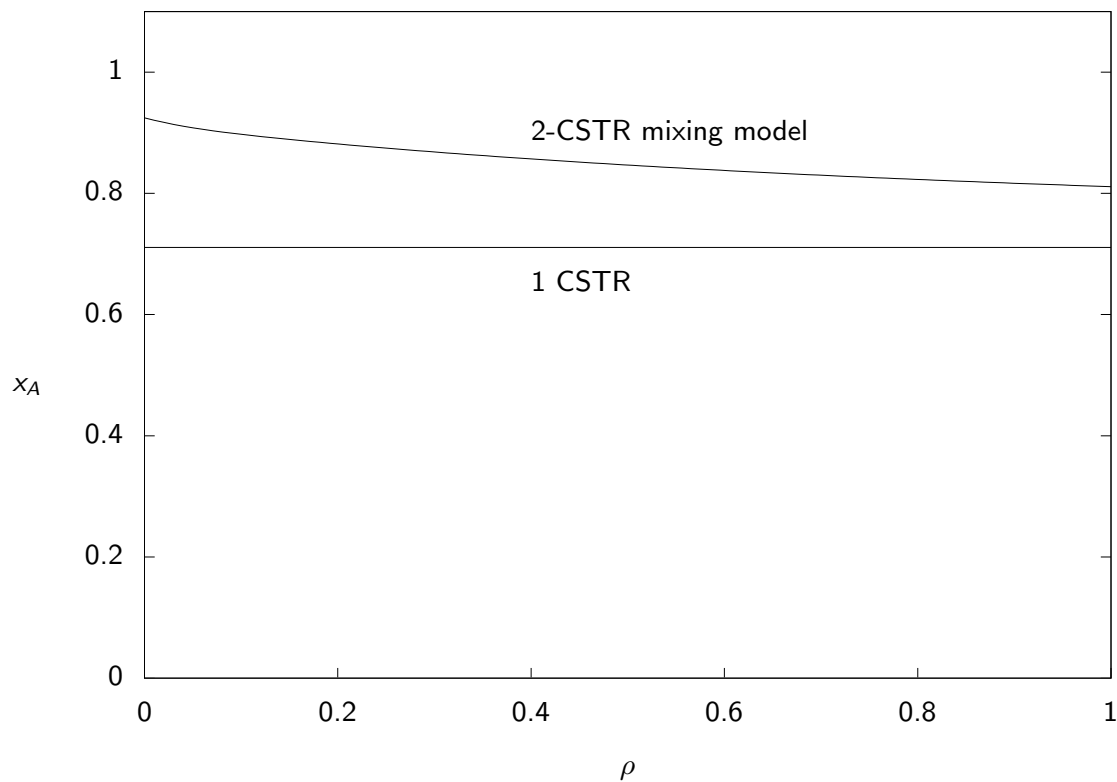
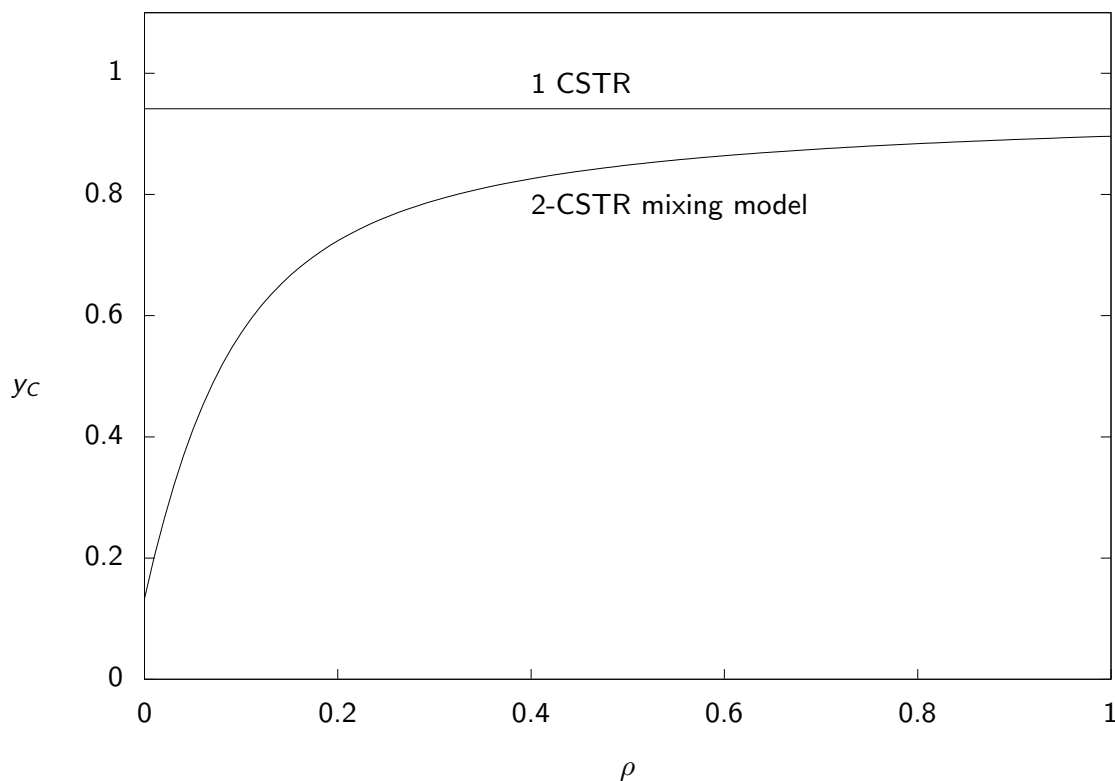

Figure 8.33: Conversion of reactant A for single, ideal CSTR, and as a function of internal flowrate,  $\rho = Q_r/Q_2$ , in a 2-CSTR mixing model.

108 / 130

- Notice, however, that at low values of  $Q_r$ , which corresponds to poor mixing at the feed location, the yield changes from *more than 90%* to *less than 15%*.
- Low yield is a qualitatively different problem than low conversion. If the conversion is low, we can design a separation system to remove the unreacted A and recycle it, or use it as feed in a second reactor.
- With low yield, however, the A has been irreversibly converted to an undesired product D. The raw material is lost and cannot be recovered.
- It is important to diagnose the low yield as a reactor mixing problem, and fix the problem at the reactor. A yield loss cannot be recovered by downstream processing.

109 / 130



110 / 130

Figure 8.34: Yield of desired product C for single, ideal CSTR, and as a function of internal flowrate,  $\rho = Q_r/Q_2$ , in a 2-CSTR mixing model.

111 / 130

## Solution — residence-time distribution I

- Next we compute the outcome of injecting a unit step change in a tracer in the A feed stream.
- We solve the transient CSTR balances and calculate the tracer concentration at the outlet.
- Because the tracer does not take part in any reactions, this can be done analytically or numerically. The result is shown in Figure 8.35.

112 / 130



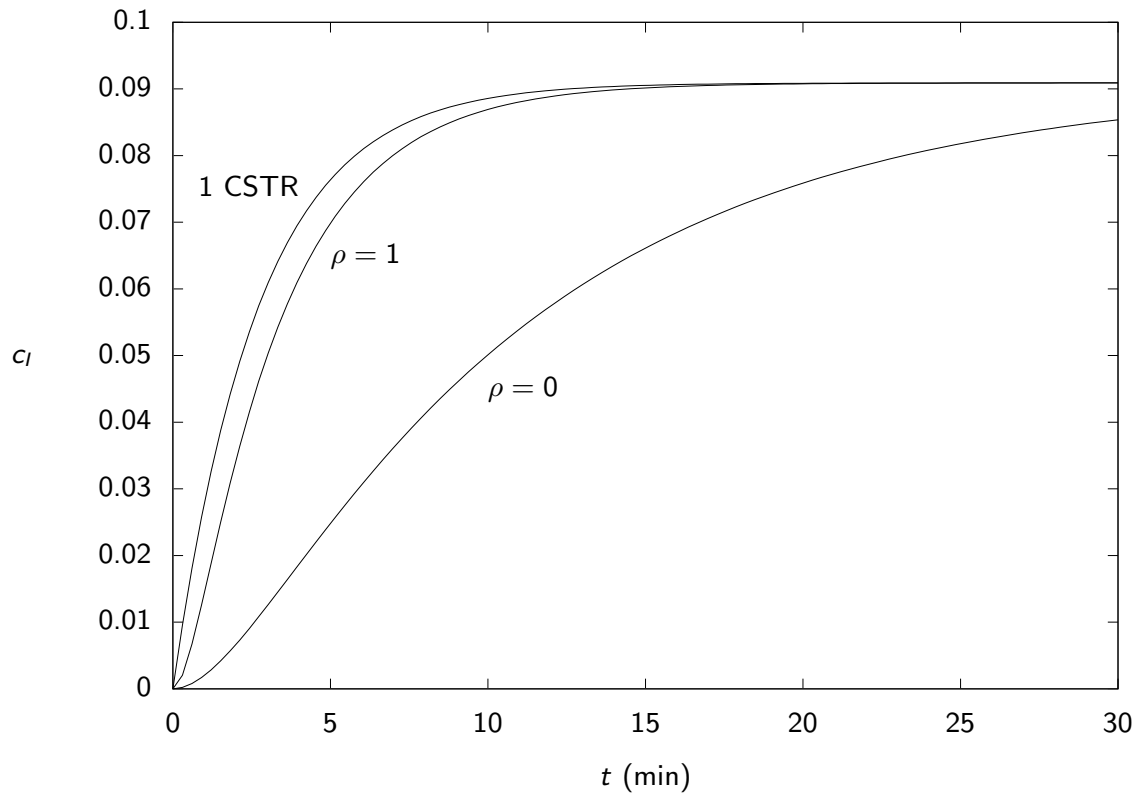

Figure 8.35: Step response for single, ideal CSTR, and 2-CSTR mixing model with  $\rho = 0, 1$ .

113 / 130

## RTD diagnoses the problem well

- We see the familiar single-CSTR step response.
- For the two-reactor mixing model, when  $\rho = 0$ , which corresponds to the poorest mixing and lowest yield, the step test does reliably indicate the poor mixing. At the end of this chapter and also in Chapter 9 we show how to use this step response to determine the best value of  $\rho$  to model the mixing.
- When  $\rho$  is reasonably large,  $Q_r = Q_2$ , and the single CSTR and two-reactor cases have similar yields and step responses.
- Notice in all three step responses, the tracer concentration reaches only  $c_{Is} = 0.091 = \alpha/(1 + \alpha)$  because we inject tracer in only one of the two feed streams.

114 / 130

- This example is one of the classic sets of reactions in which mixing has a significant impact on the reactor performance and the product yield.
- It deserves careful study because it builds intuition and leads us to ask good questions when confronted with more complex cases.
- For example, Villa et al. [17] discuss similar issues that arise in more complex polymerization reaction engineering problems.

## Maximizing yield in dispersed plug flow

### Example 8.6: Maximizing yield in dispersed plug flow

Consider the following two liquid-phase reactions in which B is the desired product

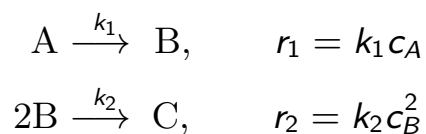

The second reaction can represent the first step in a polymerization process of species B, which is undesirable in this case.

Because the second reaction is second order in B, it is desirable to keep the *average* B concentration in the reactor low, to avoid yield losses, but achieve high B concentration near the reactor exit to maximize the production rate. Intuitively the CSTR is a bad choice, because it maintains the same B concentration everywhere in the reactor. A PFR should offer higher yield. The B concentration is low near the tube entrance, and increases to its maximum value at the tube exit if we choose the right length or residence time. If we make the tube too long, however, the B is largely converted to C and the yield is again low. In this case, yield is adversely affected by mixing.

Calculate the steady-state conversion of A and yield of B versus PFR length for the kinetic and reactor parameters in Table 8.4. What is an appropriate reactor length to maximize yield of B? Study the effect of dispersion. Approximately how large can the dispersion number be before the advantages of the PFR over the CSTR are lost? □

Parameter	Value	Units
$k_1$	1	$\text{min}^{-1}$
$k_2$	1	$\text{L/mol}\cdot\text{min}$
$c_{Af}$	1	$\text{mol/L}$
$c_{Bf}$	0	
$v$	1	$\text{m/min}$
$l$	0.5	$\text{m}$
$D_l$	varies	$\text{m}^2/\text{min}$

Table 8.4: Parameters for the dispersed PFR example.

## Solution I

The steady-state mass balances for components A and B are

$$v \frac{dc_A}{dz} - D_l \frac{d^2 c_A}{dz^2} = R_A$$

$$v \frac{dc_B}{dz} - D_l \frac{d^2 c_B}{dz^2} = R_B$$

in which

$$R_A = -k_1 c_A, \quad R_B = k_1 c_A - 2k_2 c_B^2$$

and we have assumed the dispersion numbers of both species are the same,  $D_{Al} = D_{Bl} = D_l$ . Because the fluid is a liquid, we assume the velocity is constant. We use Danckwerts boundary conditions for both species

$$vc_{jf} = vc_j(0) - D_l \frac{dc_A}{dz}(0), \quad z = 0$$

$$\frac{dc_j}{dz} = 0, \quad z = l$$

$j = (A, B)$ . Given the concentrations, and because the flowrate is constant, the conversion and yield are

$$x_A = \frac{c_{Af} - c_A}{c_{Af}} \quad y_B = \frac{c_B}{c_{Af} - c_A}$$

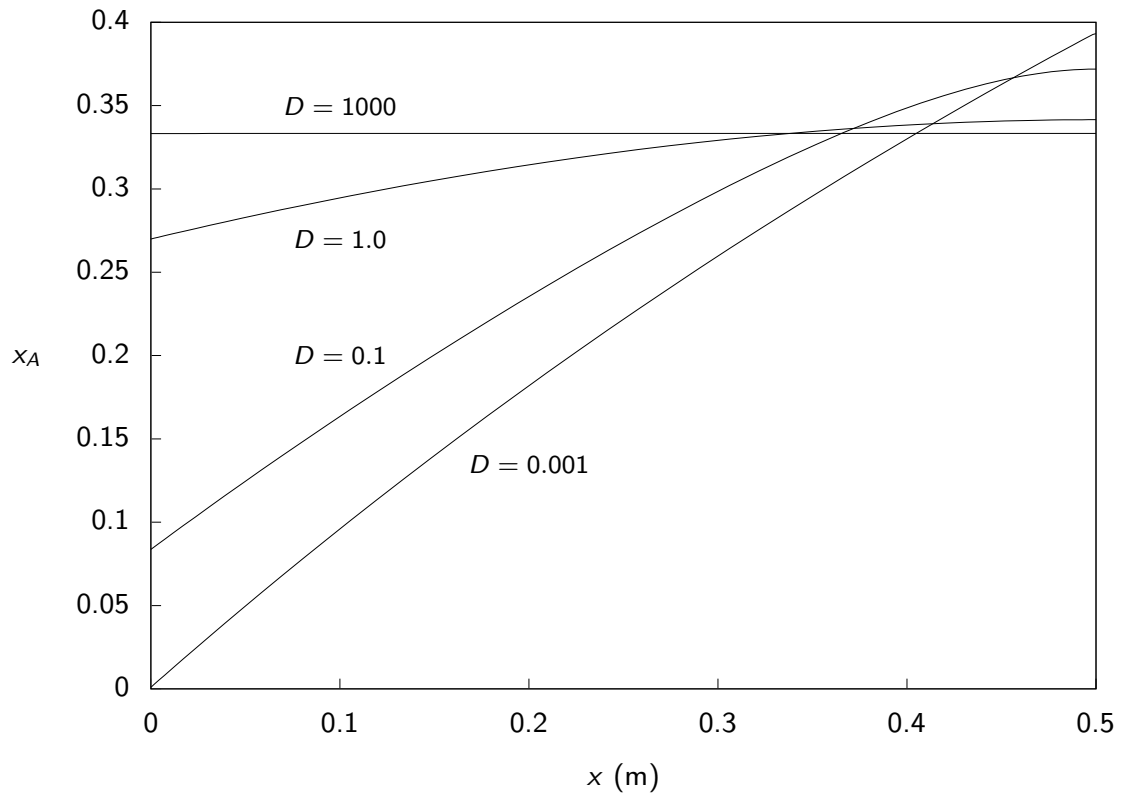

Figure 8.36: Conversion of reactant A versus reactor length for different dispersion numbers.

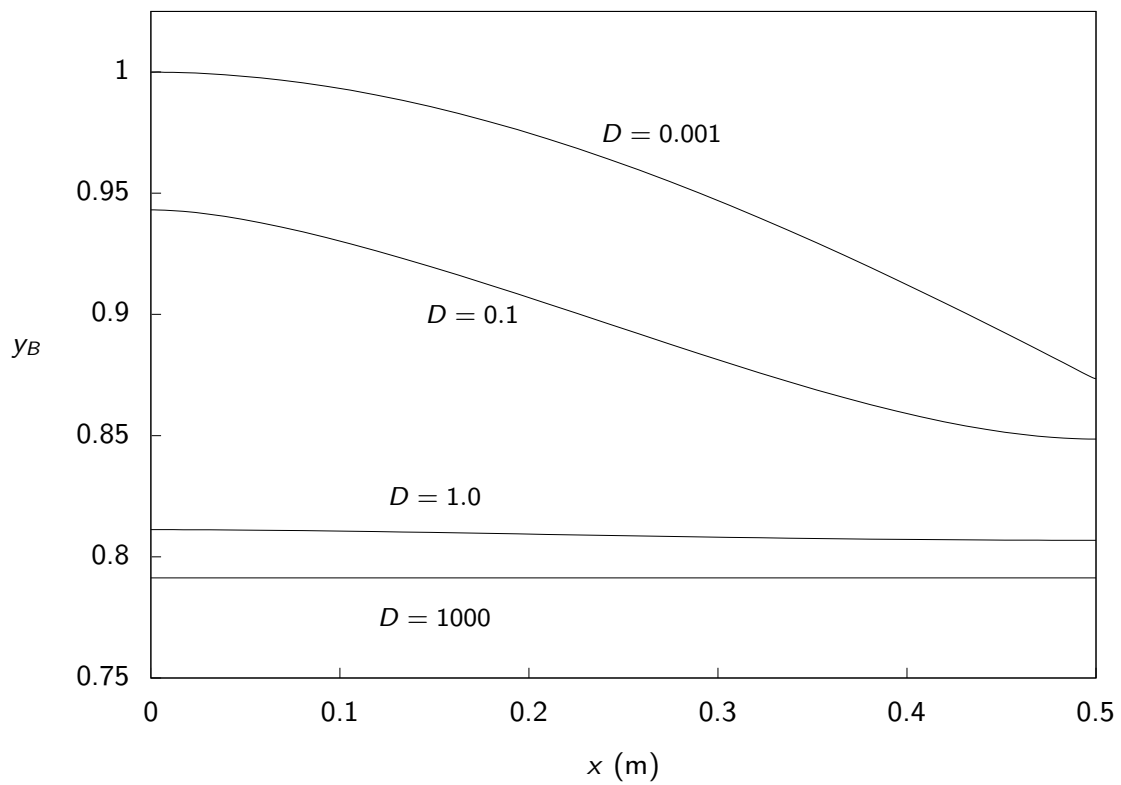

Figure 8.37: Yield of desired product B versus reactor length for different dispersion numbers.

Figures 8.36 and 8.37 show the conversion of A and yield of B versus tube length for a tube designed to maximize the yield of B. A tube length of about 0.5 m is appropriate. As the length increases above this value, the conversion of A increases, but the yield of B drops rapidly, defeating the main purpose of using a PFR. For the kinetic parameters chosen, the CSTR yield can be improved by about 8% with a PFR. As shown in Figure 8.36, the high-dispersion PFR is essentially a CSTR, and achieves  $y_B = 0.79$ . The PFR with  $D = 0.001$  achieves  $y_B = 0.87$ . We see that the dispersion number must be kept less than about 0.1 to maintain this advantage in yield.

## Summary

- In this chapter we generalized the two flow assumptions of the idealized reactor models: the perfect mixing assumption of the batch reactor and CSTR, and the plug-flow assumption of the PFR.
- We defined the residence-time distribution (RTD) of a reactor, and showed how to measure the RTD with simple tracer experiments such as the step test, pulse test and (idealized) impulse test.
- The RTD gives a rough measure of the flow pattern in the reactor, but it does not determine completely the reactor performance. Indeed, reactors with different flow patterns, and therefore different performances, may have identical RTDs.

- We showed the CSTR has an exponential RTD. The derivation of the RTD of the CSTR also illustrated the following general principle: given an event with constant probability of occurrence, the time until the next occurrence of the event is distributed as a decreasing exponential function. This principle was used, for example, to choose the time of the next reaction in the stochastic simulations of Chapter 4.
- The residence-time distribution of the PFR was shown to be arbitrarily sharp because all molecules spend identical times in the PFR. We introduced the delta function to describe this arbitrarily narrow RTD.
- We added a dispersion term to the PFR equations to model the spread of the RTD observed in actual tubular reactors. Introducing the dispersion term's second derivative necessitates new boundary conditions different from the PFR's. These are called Danckwerts boundary conditions.
- We computed the full, transient behavior of the dispersed plug-flow model, and displayed the evolution of the concentration profile after a step change in the feed concentration.

## Reactor mixing limits

- We then examined the limits of reactor mixing consistent with a given RTD. The two limits are segregated flow and maximum mixedness.
- We showed how a physical process such as mass transfer between a continuous phase and a particle phase can approach segregated flow for large particles (small mass-transfer rates) and can approach maximum mixedness for small particles (high mass-transfer rates).
- We also showed that the mixing limits bound the possible reactor behavior for the case of a single, convex reaction-rate expression.
- For more general reaction networks, however, the mixing limits do not bound the reactor performance. For the general reaction network, recent research on the attainable region has started to shed light on the possible reactor performance.







- Next we discussed two contrasting cases in which mixing plays a critical role. In the mixing of two liquid reactants, we showed that formation of a poorly mixed zone can lead to significant yield losses.
- By contrast, for the kinetics of the second example, good mixing leads to yield losses; in this example the reactor should be designed to approach segregated flow.
- Finally, the recent progress in the area of computational fluid dynamics (CFD) gives us reason to believe that direct solution of the equations of motion for the fluid will be a tractable approach for designing reactors and evaluating their performance [1].
- It seems reasonable to expect the classical RTD methods and simple flow models to complement the computationally intensive CFD methods. CFD methods may be used to validate simpler mixing models. These validated, simple mixing models may continue to play important roles in reactor analysis, design and optimization.

## Notation I

$c_e$	effluent concentration in RTD measurement
$c_f$	feed concentration
$c_j$	concentration of species $j$
$c_m$	concentration in a maximally mixed flow model
$c_s$	concentration in a segregated flow model
$c_\infty$	concentration boundary condition in maximum mixedness model
$D$	dimensionless dispersion number, $D = D_I \tau / l^2$
$D_A$	molecular diffusivity
$D_{jl}$	dispersion coefficient for species $j$
$D_I$	dispersion coefficient
$\text{erf}(x)$	error function, Equation 8.25
$H(x)$	Heaviside or unit step function, Equation 8.13
$k_{mj}$	mass-transfer coefficient
$l$	tubular reactor length
$n$	number of CSTRs in a mixing model
$p(\theta)$	probability that a molecule spends time $\theta$ to $\theta + d\theta$ in reactor, RTD
$P(\theta)$	probability that a molecule spends time zero to $\theta$ in the reactor, integrated form of the RTD
$Pe$	Péclet number, $Pe = vl / D_A$
$Q$	volumetric flowrate
$Q_f$	feed volumetric flowrate







$r$	particle radius in mixing model
$r$	reaction rate of (single) reaction
$R_j$	production rate of species $j$
$v$	fluid axial velocity
$V_R$	reactor volume
$x_j$	molar conversion of component $j$
$y_j$	yield of species $j$
$z$	reactor length variable
$\gamma(n, x)$	incomplete gamma function of order $n$ and argument $x$
$\Gamma(n)$	gamma function of $n$
$\delta(x)$	delta or impulse function, Equations 8.5 and 8.14
$\theta$	residence time of tracer molecule in reactor
$\bar{\theta}$	mean residence time, $\bar{\theta} = \int_0^{\theta} \theta' p(\theta') d\theta'$
$\lambda$	time-to-go before molecule exits reactor
$\tau$	$V_R/Q_f$

## References I

- 
[A. Bakker, A. H. Haidari, and E. M. Marshall.](#)  
 Design reactors via CFD.  
*Chem. Eng. Prog.*, pages 30–39, December 2001.
- 
[J. F. Burri, S. D. Wilson, and V. I. Manousiouthakis.](#)  
 Infinite dimensional state-space approach to reactor network synthesis: Application to attainable region construction.  
*Comput. Chem. Eng.*, 26(6):849–862, 2002.
- 
[S. P. Chauhan, J. P. Bell, and R. J. Adler.](#)  
 On optimum mixing in continuous homogeneous reactors.  
*Chem. Eng. Sci.*, 27:585–591, 1972.
- 
[P. V. Danckwerts.](#)  
 Continuous flow systems: Distribution of residence times.  
*Chem. Eng. Sci.*, 2:1–13, 1953.
- 
[M. Feinberg.](#)  
 Toward a theory of process synthesis.  
*Ind. Eng. Chem. Res.*, 41(16):3751–3761, 2002.
- 
[M. Feinberg and P. Ellison.](#)  
 General kinetic bounds on productivity and selectivity in reactor-separator systems of arbitrary design: I. Principles.  
*Ind. Eng. Chem. Res.*, 40(14):3181–3194, 2001.
- 
[M. Feinberg and D. Hildebrandt.](#)  
 Optimal reactor design from a geometric viewpoint — I. Universal properties of the attainable region.  
*Chem. Eng. Sci.*, 52(10):1637–1665, 1997.









## References II

-  D. Glasser, D. Hildebrandt, and S. Godorr.  
The attainable region for segregated, maximum mixed and other reactor models.  
*Ind. Eng. Chem. Res.*, 33:1136–1144, 1994.
-  D. Hildebrandt and D. Glasser.  
The attainable region and optimal reactor structures.  
*Chem. Eng. Sci.*, 45:2161–2168, 1990.
-  F. J. M. Horn.  
Attainable and non-attainable regions in chemical reaction technique.  
In *Proceedings of the third European Symposium on Chemical Reaction Engineering*, pages 293–302, London, UK, 1964. Pergamon Press.
-  A. C. Kokossis and C. A. Floudas.  
Synthesis of isothermal reactor-separator-recycle systems.  
*Chem. Eng. Sci.*, 46(5/6):1361–1383, 1991.
-  A. Lakshmanan and L. T. Biegler.  
Synthesis of optimal chemical reactor networks.  
*Ind. Eng. Chem. Res.*, 35:1344–1353, 1996.
-  I. Langmuir.  
The velocity of reactions in gases moving through heated vessels and the effect of convection and diffusion.  
*J. Am. Chem. Soc.*, 30(11):1742–1754, 1908.
-  O. Levenspiel.  
*Chemical Reaction Engineering*.  
John Wiley & Sons, New York, third edition, 1999.

129 / 130

## References III

-  E. B. Nauman and B. A. Buffham.  
*Mixing in Continuous Flow Systems*.  
John Wiley & Sons, New York, 1983.
-  J. M. Ottino.  
*The kinematics of mixing: stretching, chaos and transport*.  
Cambridge University Press, Cambridge, 1989.
-  C. M. Villa, J. O. Dihora, and W. H. Ray.  
Effects of imperfect mixing on low-density polyethylene reactor dynamics.  
*AIChE J.*, 44(7):1646–1656, 1998.
-  J. V. Villadsen and W. E. Stewart.  
Solution of boundary-value problems by orthogonal collocation.  
*Chem. Eng. Sci.*, 22:1483–1501, 1967.
-  H. Weinstein and R. J. Adler.  
Micromixing effects in continuous chemical reactors.  
*Chem. Eng. Sci.*, 22:65–75, 1967.
-  S. W. Weller.  
Langmuir as chemical engineer. . . or, from Danckwerts to Bodenstein and Damköhler.  
*Chem. Eng. Ed.*, 28:262–264, 1994.
-  T. N. Zwietering.  
The degree of mixing in continuous flow systems.  
*Chem. Eng. Sci.*, 11:1–15, 1959.

130 / 130